

# Drinking Fountain: A280

The Apollo 280 combines all the features, design and versatility of the new BF200 refill fountain with the more traditional features of our standard Apollo range. It comes with the option of the longer basin making the A280 more disabled accessible and user friendly. With its newly designed stainless steel basin and a stainless steel feature front panel, the Apollo 280 is not only practical but very stylish and will compliment any contemporary urban streetscape

## Dimensions

- Total Height: 900mm
- Clearance Height: 800mm
- 191mm x 160mm base

## Water Receptacle

- 316 stainless steel catchment tray
- Nozzle material 316 stainless steel
- Easy push button water activator

## Plumbing

- 1/2 water inlet
- 40mm waste outlet pipe

## Finishes

- Primed and Powder coated finish (Available in many different colours. Please see colour selector)
- Stainless Steel
- Anti graffiti (available on request)

## Fixings

- Surface mounted with Dyna bolts or in ground fixings with foundation cage
- All internal bolts
- 316 Stainless steel security screws

## Options

- Optional tap and dog bowl
- Optional catchment tray
- Water filter
- Logo or motif
- Longer or shorter basin
- Optional side protection panels

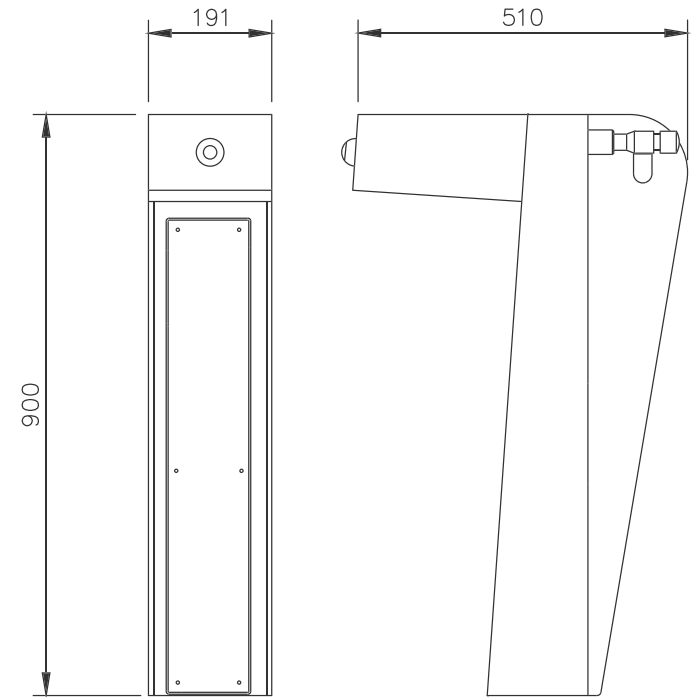

**WaterMark**

CMA-WM-080042  
WMTS-105:2016



[www.urbanff.com.au](http://www.urbanff.com.au)

07 3382 7372

office@urbanff.com.au

*Urban*  
fountains + furniture