

# Drinking Fountain: Apollo 900

The Apollo 900 is a new, sleekly formed stainless steel fountain with a uniquely tapered body and integrated basin. It is durable and vandal resistant like all our outdoor disabled accessible fountains. This “big brother” to the Apollo 300 keeps many of its practical functionalities with an updated body design.

- Dimensions**
- Total Height: 860mm
  - Clearance Height: 760mm
  - 200mm x 100mm tapered stainless steel
  - One piece heavy duty construction
- Plumbing**
- In built water pressure regulator ½' inlet
  - 40mm Waste outlet pipe
- Finishes**
- Primed and powder coated  
(Available in many different colours. [See colour selector](#))
  - Stainless steel
  - All fountains come with vandal resistant 316 stainless steel security screws
- Options**
- Tap and Dog Bowl
  - Optional tap available
  - Full parts and technical back up service available.
  - Service kits available for purchase.

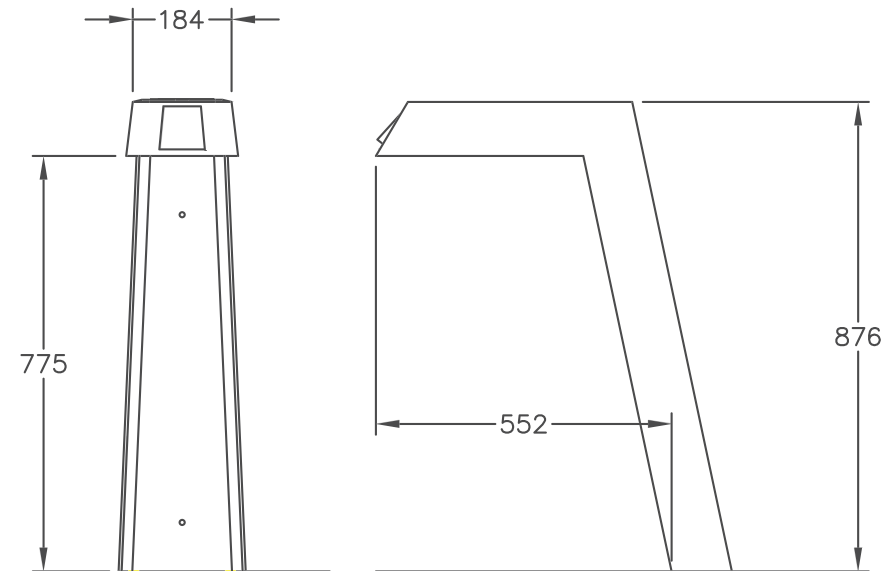

**WaterMark**

CMA-WM-080042  
WMTS-105:2016



[www.urbanff.com.au](http://www.urbanff.com.au)

07 3382 7372

[office@urbanff.com.au](mailto:office@urbanff.com.au)

*Urban*  
fountains + furniture