

Pet // Drinking Fountain: PF600

Our pet accessible fountain enables dog lovers to provide fresh drinking water for their dogs whilst out in public places. The PF 600 is becoming increasingly popular with local councils for use in their off leash areas in parks providing water for owners and their dogs.

The common “post bubblers” with tap attachments, usually with a plastic bowl placed by a considerate dog owner, is unsightly and will soon be a thing of the past with the introduction of the PF 600. Excess water is directed in to the dog bowl which can be emptied by a simple tipping of the bowl.

- Dimensions**
- Total height: 987mm
 - Width: 257mm
 - Dog bowl height: 150mm

- Finishes**
- Hot spray galvanised
 - Primed and Powdercoated
(Available in many different colours. [See colour selector](#))

- Options**
- Maintenance tap
 - Stainless steel

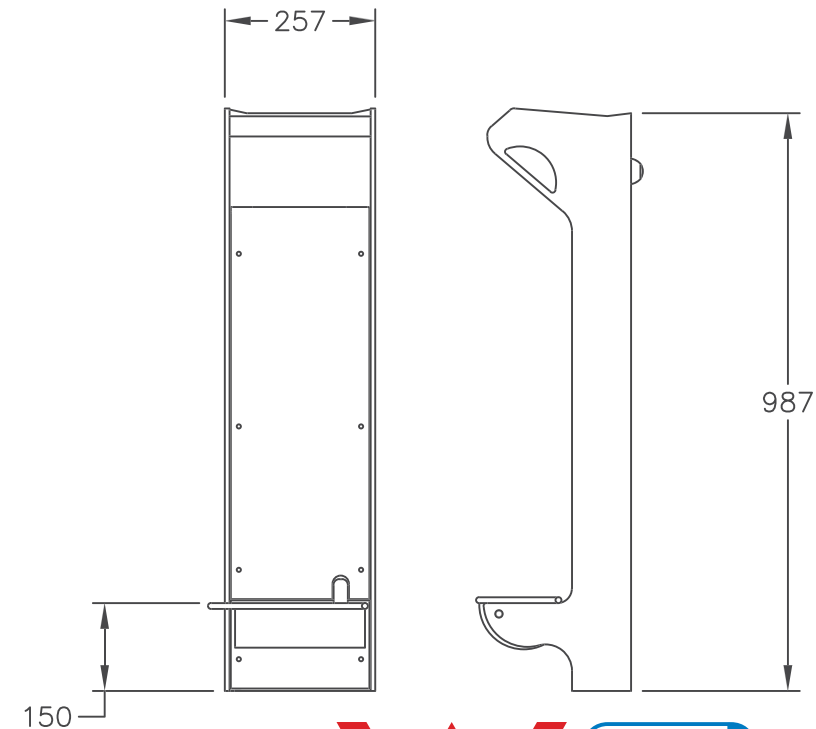

WaterMark

CMA-WM-080042
WMTS-105:2016



www.urbanff.com.au

07 3382 7372

office@urbanff.com.au

Urban
fountains + furniture