

Drinking Fountain: Apollo 880

The sleek new Apollo 880 stainless steel fountain features a uniquely curved angled body like no other design in the current market. Like all Urban's outdoor disabled accessible fountains, it is durable and vandal resistant. The Apollo 880 is the "big sister" to the Apollo 800, and follows on from that popular design. It retains many of the practical functionalities of that model with just a newer, more dynamic body design.

- Dimensions**
- Total Height: 915mm
 - Clearance Height: 846mm
 - Base: 300mm x 200mm Tapered to top
 - One piece heavy duty construction
 - Easy access grab rail

- Water Receptacle**
- 316 Stainless steel basin
 - Nozzle material 316 stainless steel
 - Stainless steel easy action activator lever

- Plumbing**
- In built water pressure regulator ½' inlet
 - 40mm Waste outlet pipe

- Finishes**
- Primed and powder coated as standard (Available in many different colours. [Please see colour selector](#))
 - Stainless steel finish (optional)
 - Anti graffiti

- Fixings**
- Surface mounted with Dyna bolts or in ground fixings with foundation cage
 - All bolts internal
 - All fountains come with vandal resistant 316 stainless steel security screws

- Options**
- Tap and dog bowl
 - Full parts and technical back up service available
 - Service kits available for purchase

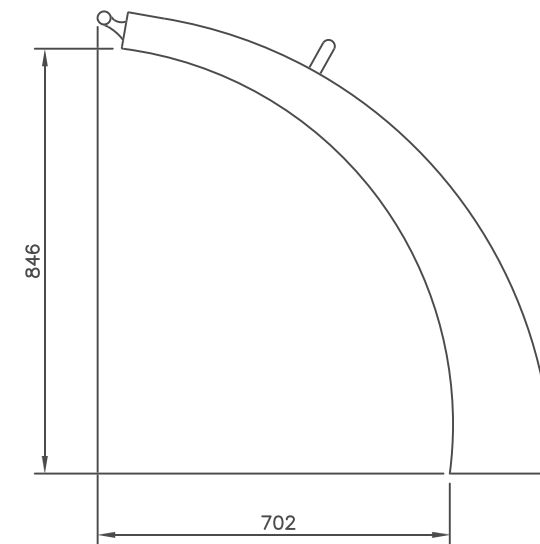
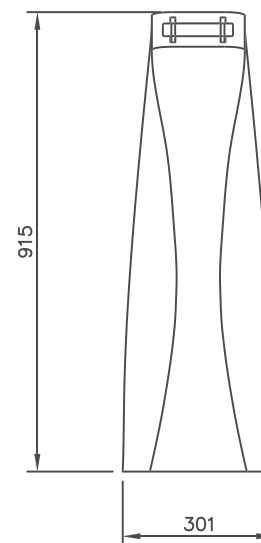

WaterMark

CMA-WM-080042
WMTS-105:2016



www.urbanff.com.au

07 3382 7372
office@urbanff.com.au

Urban
fountains + furniture