

ARCHITECTURAL FOUNTAINS | PF400 PET DRINKING FOUNTAIN

SPECIFICATION SHEET

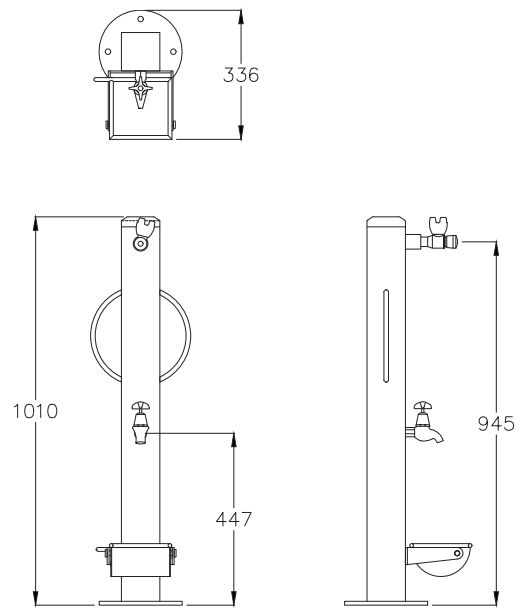

MODEL

Model: PF400 Pet Friendly Fountain
SKU: DFPPF400SURF
DFPPF400SURFBF (with bottle filler)

DIMENSIONS

Total Height: 1000mm
Width: 100mm
Dog bowl height: 170mm

CERTIFICATIONS



FEATURES

- + RHS Steel Construction
- + 316 S/S Fixings
- + Australian Made
- + Vandal resistant
- + Watermark Certified
- + Surface Mounted

OPTIONS

- + Bottle Filler
- + Maintenance Tap
- + Full Stainless Steel Body Finish
- + Tap Protector Shrouds
- + Leash Handles
- + Inground Fixings

POPULAR COLOURS



COAST



STORM



DESERT



FLAME



LEAF



EVERGREEN



MONUMENT



STAINLESS STEEL