

# ARCHITECTURAL FOUNTAINS | PF450 PET DRINKING STATION

## SPECIFICATION SHEET

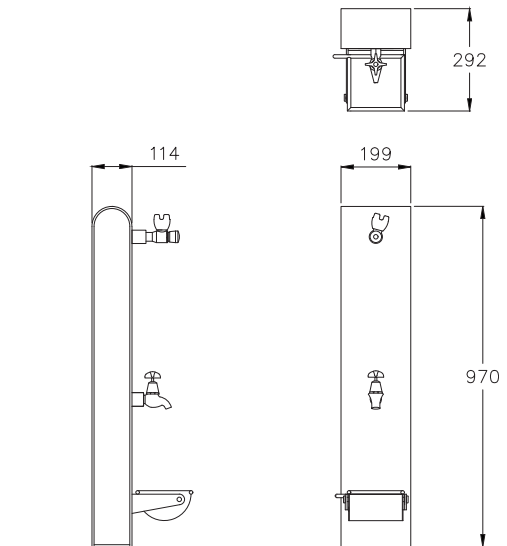

### MODEL

**Model:** PF450 Pet Friendly Fountain  
**SKU:** DFPP450  
DFPP450BF (with bottle filler)

### DIMENSIONS

**Total Height:** 970mm  
**Width:** 199mm  
**Depth:** 114mm

### CERTIFICATIONS



### FEATURES

- + Heavy Duty One Piece 6mm Steel Construction
- + 316 S/S Fixings
- + Recycled Plastic or S/S side panels
- + Australian Made
- + Vandal resistant
- + Surface Mounted
- + Concealed Fixings

### OPTIONS

- + Bottle Filler
- + Maintenance Tap
- + Full Stainless Steel Body Finish
- + Tap Shrouds
- + Carbon Filter
- + Anti Graffiti Coating
- + Artwork - Logo/Plaque/Vinyl wrap

### POPULAR COLOURS

