

ARCHITECTURAL FOUNTAINS | APOLLO 450 PET DRINKING STATION

SPECIFICATION SHEET

Urban
+ Fountains
+ Furniture

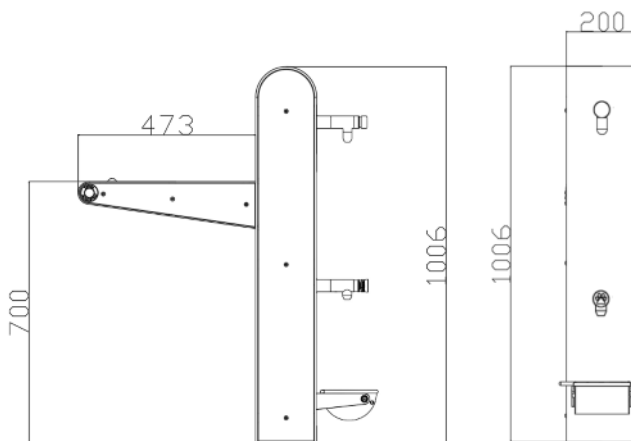

MODEL

Model: A450 Pet Friendly Fountain

SKU: DF450

DIMENSIONS

Total Height: 1006mm

Width: 200mm

CERTIFICATIONS



FEATURES

- + Heavy Duty One Piece Steel Construction
- + 316 S/S Fixings
- + Stainless Steel Side Panels
- + AS1428 DDA Compliant
- + Single touch activation valve
- + Bottle Filler as standard
- + Bubbler
- + Tap & Dog Bowl
- + Australian Made

OPTIONS

- + Maintenance Tap
- + Full Powdercoated Body
- + Tap Shrouds
- + Carbon Filter
- + Anti Graffiti Coating
- + Artwork - Logo/Plaque/ Vinyl wrap
- + Remove Tap & Dog Bowl

POPULAR COLOURS

