

ARCHITECTURAL FOUNTAINS | BF400P BOTTLE REFILL SERIES

SPECIFICATION SHEET

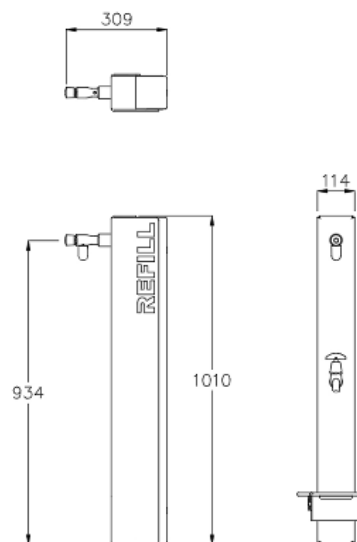

MODEL

Model: BF400P Bottle refill series

SKU: DFBF400P (plastic post with bottle refill only)

DFBF400PD (plastic post with bottle refill and tap and dog bowl)

DIMENSIONS

Total Height: 1010mm

Width: 114mm x 309 mm

CERTIFICATIONS



FEATURES

- + Strong and durable Galvanised Steel construction
- + Sustainable Circular Economy design
- + Modular design for flexibility/retrofit Recycled Timber Post
- + Recycled Plastic Post
- + Australian Made
- + Vandal resistant
- + Surface Mounted
- + Concealed Fixings

OPTIONS

- + Tap and Dog Bowl
- + Maintenance Tap
- + Tap Shrouds
- + Carbon Filter
- + Artwork - Logo/Plaque/ Vinyl wrap
- + Powder Coated
- + Stainless Steel

POPULAR COLOURS



COAST



STORM



DESERT



FLAME



LEAF



EVERGREEN



MONUMENT



STAINLESS