

ARCHITECTURAL FOUNTAINS | PF450 PET DRINKING STATION

SPECIFICATION SHEET

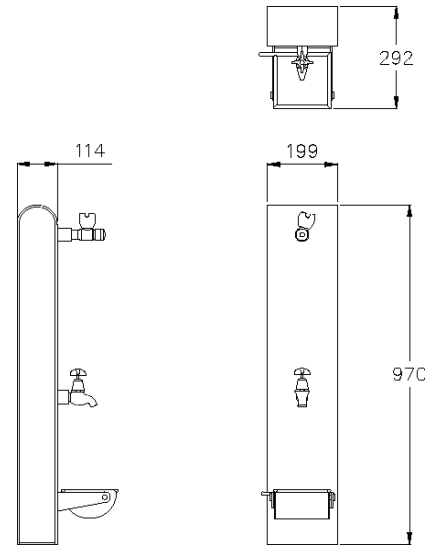

MODEL

Model: PF450 Pet Friendly Fountain
SKU: DFPF450
 DFPF450BF (with bottle filler)

DIMENSIONS

Total Height: 970mm
Width: 199mm
Depth: 114mm

CERTIFICATIONS



FEATURES

- + Heavy Duty One Piece 6mm Steel Construction
- + 316 S/S Fixings
- + Recycled Plastic or S/S side panels
- + Australian Made
- + Vandal resistant
- + Surface Mounted
- + Bubblers
- + Tap & Dog Bowl
- + Concealed Fixings

OPTIONS

- + Bottle Filler
- + Maintenance Tap
- + Full Stainless Steel Body Finish
- + Tap Shrouds
- + Carbon Filter
- + Anti Graffiti Coating
- + Artwork - Logo/Plaque/ Vinyl wrap

POPULAR COLOURS

