

ENHANCING OUTDOOR SPACES

2026

urban+



MAKING LIFE BETTER

urban fountains and furniture

URBAN CATALOGUE

www.urbanff.com.au

urban +

INDEX

	PAGE
+ INTRODUCTION	1
+ CIRCULAR ECONOMY	2
+ PRODUCT DESIGN ETHOS	3
+ DRINKING FOUNTAIN + REFILL STATIONS	4-19
+ SEATS AND DAY BED	20-25
+ PICNIC TABLE	26-29
+ BIKE RACKS	30-33
+ OUTDOOR SHOWERS	34-37
+ TREE GRATES AND GUARDS	38-41
+ BOLLARDS + BALUSTRADING	42-45
+ BINS AND ENCLOSURES	46-49
+ DOG PARK AGILITY EQUIPMENT	50-53
+ CLIENTS AND PROJECTS	54
+ VANDALISM PROTECTION WARRANTY	55
+ CONTACT US	56

URBAN FOUNTAINS & FURNITURE

Making Life Better

+ We believe there is a better way to do business

Our **mission** is to support the shift to a circular economy by supplying sustainable drinking fountains and street furniture that not only enhance public spaces but can remain in use for generations to come.

+ Australian owned & operated

Urban+ is a proud Australian business **since 2001**. We understand Australia's needs, including the need to reduce waste and have built that into our product designs, business programs, and operations. Our goal is to keep the Australian manufacturing industry strong by paving the way in sustainable business practices.

+ About

At **Urban+** we believe there is a better way to do business. Our mission is to support the shift to a circular economy by supplying sustainable drinking fountains and street furniture that not only enhance public spaces but can remain in use for generations to come.

+ How

- + **create** products that last
- + **offer** customers a range of sustainability-focused programs
- + **reduce** waste entering landfill and drive water conservation



URBAN FOUNTAINS & FURNITURE

Making Life Better

? How does the circular economy work?

Our programs

- + **Choose your Urban+ experience** Select from our subscription, service & maintenance and ownership options
- + **Restore + Refill program** Join our restoration program and restore your Urban+ drinking fountain to like 'new'
- + **Conservation commitment** By choosing our products you are supporting waste reduction, water conservation and single-use plastic bottle elimination
- + **Trade-in program** Trade-in your old drinking fountain to keep it out of landfill and we will give you an allowance. We will also refurbish and gift the fountain to a charity of your choice

Urban+ values

- + **Sustainability** We design products that last. To further stretch our product's lifespan for generations, we have created smart and sustainable programs to lead the way for our industry and drive the circular economy
- + **Product design** Our seamless design approach means the things you don't see are just as important as the things you do. We pride ourselves on visual aesthetic and match it equally with durability and function
- + **Craftmanship** Delivering the highest quality crafted finishes. We're best in class with our fabrication process, functionality, and durability

linear economy

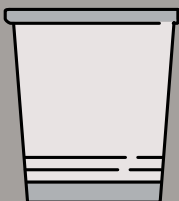
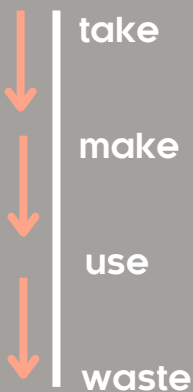

recycling economy

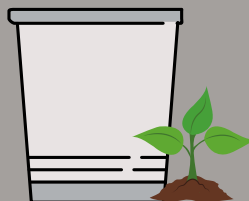
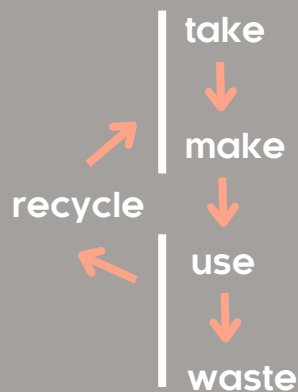

circular economy

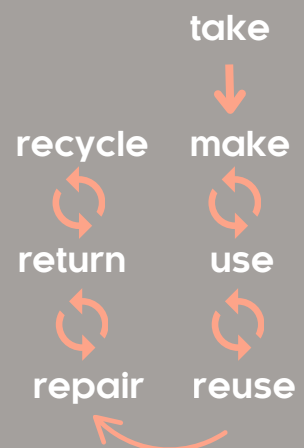

URBAN FOUNTAINS & FURNITURE

Making Life Better

PRODUCT DESIGN ETHOS

- + Our material choices and product design features are focused on ensuring the longevity and sustainability of each product.
- + We prioritise craftsmanship over mass-produced, machine-made parts and choose to handcraft where it enhances and improves the product.
- + The product design process carefully balances the demands of manufacturing and fabrication with consumer expectations for functionality and aesthetics.
- + Our seamless design approach ensures that what's hidden is just as important as what's visible, and we do not compromise on areas that aren't immediately seen.
- + Our products are built for strength and durability, with no built-in obsolescence, and come with a guarantee for long lasting performance.
- + We use anti-vandal materials, design features, and manufacturing methods to protect against vandalism.



KEY SELLING POINTS

+ PRODUCT FEATURES

- + Australian-made products – all products are manufactured locally in our facility based in Yatala, QLD and are distributed nationally.
- + All drinking fountains are Watermark-certified
- + ISO Quality Management System certified
- + Vandal resistant
- + Disabled accessible options
- + Product branding options
- + Choose from Dulux's full powder-coated colour range
- + Customisation of standard products allowed
- + Full custom design service available
- + Service, Maintenance and Refurbishment services offered
- + Product leasing opportunity



Australian Made



Sustainably Made



DRINKING FOUNTAIN + REFILL STATIONS

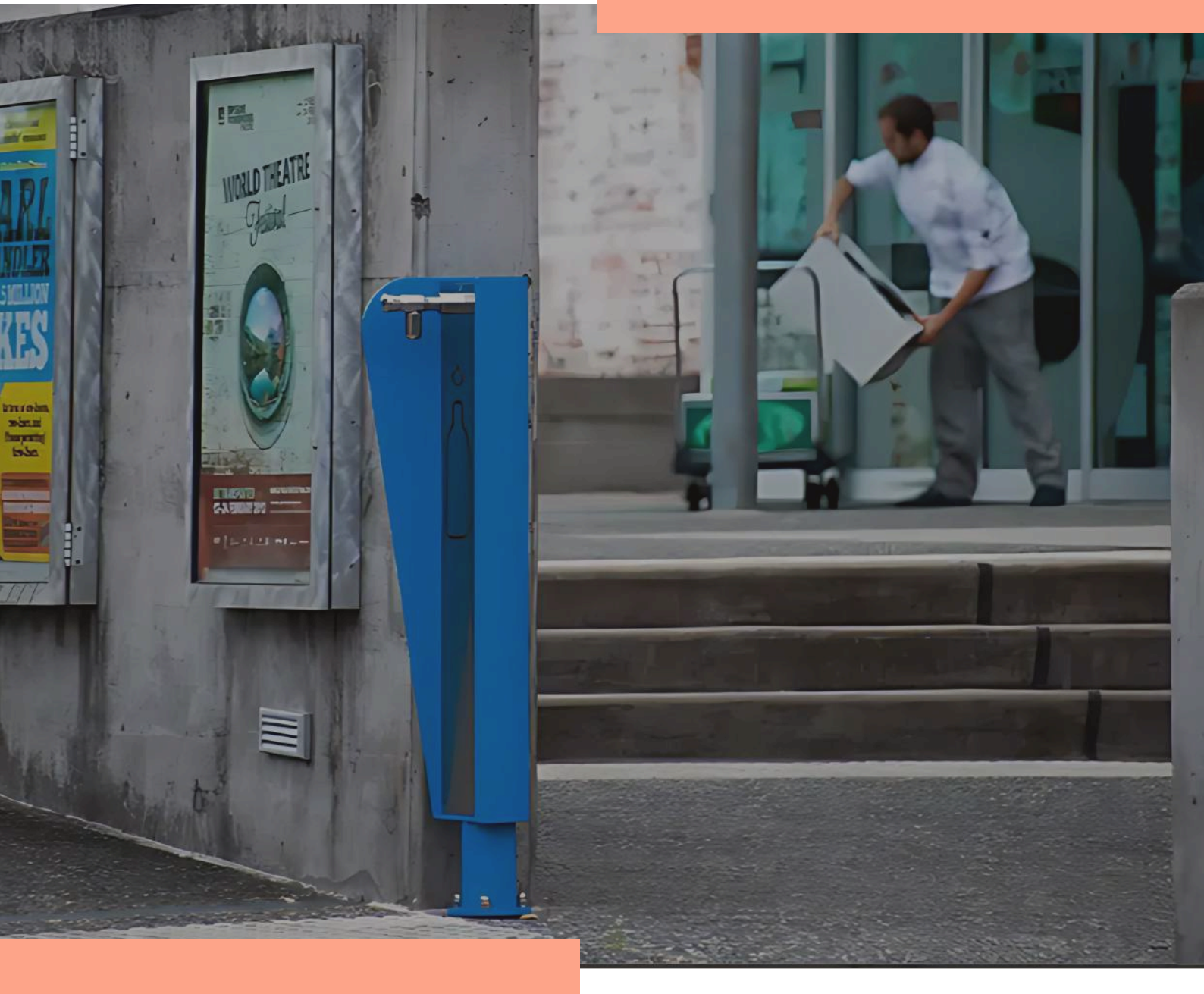

WHY CHOOSE URBAN DRINKING FOUNTAIN + REFILL STATIONS

- + **Made for Every Environment** – Designed for versatility, our fountains suit parks, schools, sporting clubs, commercial precincts, and other urban spaces.
- + **Flexible Configurations Available** – Designed to suit a variety of spaces, functions, and accessibility needs.
- + **Built to Last** – Engineered with durability, sustainability, community and timeless design in mind—ensuring long-term performance in demanding environments.
- + **Trusted by Councils and Communities Nationwide** – With over 20 years of experience, we're the preferred supplier for a wide range of public and private clients across Australia.

DRINKING FOUNTAIN + REFILL STATIONS

Drinking Fountain Solutions

+ A280

FEATURES

- + Bottle refill standard
- + Disabled accessible
- + Heavy - duty steel construction

DIMENSIONS

- + Total Height: 900mm
- + Clearance Height: 800mm
- + Base: 191mm x 160mm

- + Sand resistant activator button
- + Australian Made
- + Vandal resistant
- + Watermark-certified
- + Concealed fixings
- + Welded not bolted
- + 316 S/S basin and fixing

OPTIONS

- + Tap and Dog Bowl
- + Catchment tray
- + Maintenance tap
- + Full stainless steel body
- + Carbon filter

- + Longer basin/reduced height for AS1428 compliance
- + Artwork - logo/plaque/vinyl wrap
- + Side protection panels
- + Inground fixing cage
- + Anti graffiti coating



+ A280 Standard



+ A280 with Catchment tray & optional Maintenance tap



+ A280 with tap and dog bowl

+ A300

FEATURES

- + Disabled accessible
- + Heavy - duty steel construction
- + Welded not bolted

DIMENSIONS

- + Height: 835mm
- + Width: 200mm

- + Sand resistant activator button
- + Australian made
- + Vandal resistant
- + Watermark-certified
- + 316 S/S basin and fixings
- + Concealed fixings

OPTIONS

- + Tap and dog bowl
- + Bottle filler
- + Maintenance tap
- + Water Filter
- + Reduced height for AS1428 compliance

- + Artwork - logo/plaque/vinyl wrap
- + Inground fixing cage
- + Anti graffiti coating



+ A300 Standard



+ A300 with optional bottle filler



+ A300 with tap and dog bowl

DRINKING FOUNTAIN + REFILL STATIONS

Drinking Fountain Solutions

+ A400

FEATURES

- + Disabled accessible
- + One-piece heavy-duty construction
- + Hot dipped galvanised
- + Powder-coated finish
- + 316 S/S basin and fixings
- + Australian made
- + Vandal resistant
- + Watermark-certified

DIMENSIONS

- + Total Height: 895mm
- + Clearance Height: 730mm
- + Width: 165mm

OPTIONS

- + Tap and Dog Bowl
- + Maintenance Tap
- + Water Filter
- + Button Activated
- + Anti Graffiti Coating



+ A400 with optional tap and dog bowl



+ A400 with optional tap & dog bowl, maintenance tap and protective tap shrouds



+ A400 Standard



DRINKING FOUNTAIN + REFILL STATIONS

Drinking Fountain Solutions

+ A450

FEATURES

- + Heavy - duty one place steel construction
- + 316 S/S fixing
- + Recycled plastic or S/S side panels
- + AS1428 DDA Compliant

DIMENSIONS

- + Total Height: 1006mm
- + Width: 200mm

- + Bottle filler as standard
- + Tap & dog bowl as standard
- + Australian Made
- + Vandal resistant
- + surface mounted
- + Concealed fixings
- + Single touch activation valve

OPTIONS

- + Maintenance tap
- + Full stainless steel body
- + Tap shrouds

- + Carbon Filter
- + Anti graffiti coating
- + Artwork - logo/plaque/vinyl wrap



+ A450 Standard with powder coat finish



+ A450 Standard with optional artwork



+ A450 Standard in full Stainless Steel

+ A880

FEATURES

- + Disabled Accessible
- + 316 Stainless Steel Construction
- + Fully Welded - not bolted
- + 316 S/S Basin and Fixings

- + Easy Action lever and handle
- + Australian Made
- + Vandal Resistant
- + Watermark-certified
- + Concealed fixings

OPTIONS

- + Tap and Dog Bowl
- + Bottle Filler
- + Maintenance Tap
- + Powder-coated Finish

- + Carbon Filter
- + Inground Fixing Cage
- + Anti Graffiti Coating

DIMENSIONS

- + Total Height: 915mm
- + Clearance Height: 846mm
- + Base: 300mm x 200mm



+ A880 Standard



+ A880 Standard with optional bottle filler

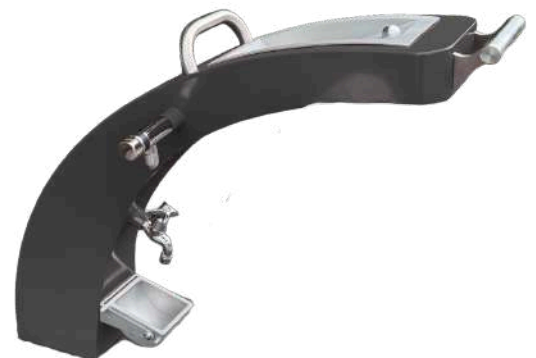

+ A880 with optional bottle filler and tap & dog bowl

DRINKING FOUNTAIN + REFILL STATIONS

Drinking Fountain Solutions

+ A900

FEATURES

- + Disabled Accessible
- + 316 Stainless Steel Construction
- + Fully Welded - not bolted
- + 316 S/S Basin and Fixings

DIMENSIONS

- + Total Height: 876mm
- + Clearance Height: 775mm
- + 200mm x 100mm Tapered Stainless steel

- + Easy Action Button
- + Australian Made
- + Vandal Resistant
- + Watermark-certified
- + Concealed fixings

OPTIONS

- + Tap and Dog Bowl
- + Bottle Filler
- + Maintenance Tap

- + Powder-Coated Finish
- + Carbon Filter
- + Inground Fixing Cage
- + Anti Graffiti Coating



+ A900 Standard



+ A900 with optional bottle filler and maintenance tap



+ A900 with optional coloured side panels



DRINKING FOUNTAIN + REFILL STATIONS

Drinking Fountain Solutions

+ A950

FEATURES

- + Solid stainless steel construction
- + Welded not bolted

DIMENSIONS

- + Height: 900mm
- + Height with signage: 1190mm
- + Base width: 440mm

- + Vandal resistant
- + Concealed fixings
- + Australian made
- + Sand-resistant push-button activation
- + Custom drainage included
- + Sleek waterfall design

OPTIONS

- + Tap and dog bowl
- + Dual basins
- + Maintenance tap
- + Water filter
- + Touchless sensor activation
- + Custom Signage/Noticeboard
- + DDA compliant option



+ A950 with optional custom notice board



+ A950 with optional custom signage/artwork



+ A950 with optional custom signage/artwork

+ BF200 WALL MOUNTED

FEATURES

- + Heavy Duty 8 mm Steel Construction
- + Fully Welded Not Bolted

DIMENSIONS

- + Total Height: 353mm
- + Width: 166mm

- + Australian Made
- + Vandal Resistant
- + WaterMark Certified
- + 316 S/S Fixings

OPTIONS

- + Catchment Tray
- + Carbon Filter
- + Anti Graffiti Coating
- + Shorter version
- + Artwork – Logo/Plaque/Vinyl wrap



+ BF200W with Catchment tray



+ BF200W Standard



+ BF200W Short

DRINKING FOUNTAIN + REFILL STATIONS

Drinking Fountain Solutions

+ BF200WM BOTTLE REFILL MULTI STRIP

FEATURES

- + 316 Stainless Steel
- + Solid Construction
- + Vandal Resistant Tap Flange
- + Easy Push Activator (self-returning)
- + Polished Finish

- + Australian Made
- + Perfect for installation above existing school bubbler troughs

OPTIONS

- + Available in 1, 2, 3 or 4 Tap Refill Strips
- + "Refill" Plaque
- + Artwork – Logo/Laser etching

DIMENSIONS

- + Total Height: 155mm
- + Width: 750mm, 1145mm, 1550mm

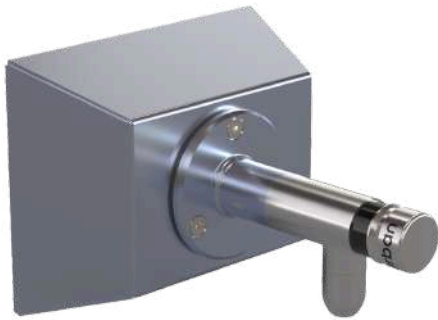

+ BF200WM single Tap



+ BF200WM Bottle Refill Multi Strip



DRINKING FOUNTAIN + REFILL STATIONS

Drinking Fountain Solutions

+ BF400

FEATURES

- + Strong and durable Galvanised Steel construction
- + Sustainable Circular Economy Design
- + Modular design for flexibility/retrofit
- Recycled Timber Post
- + Recycled Plastic Post

DIMENSIONS

- + Total Height: 1010mm
- + Width: 114mm x 309 mm

- + Australian Made
- + Vandal resistant
- + Watermark-certified
- + Concealed fixings

OPTIONS

- + Tap and Dog Bowl
- + Maintenance tap
- + Tap Shrouds
- + Carbon Filter
- + Artwork - Logo/Plaque/ Vinyl Wrap
- + Powder-coated
- + Stainless Steel



+ BF400P with dog bowl



+ BF400P Standard - Bottle refill only



+ BF400T with dog bowl



+ BF400T Standard - Bottle refill only

+ BF200 WATER BOTTLE REFILL FOUNTAIN

FEATURES

- + Heavy - duty 8mm Steel construction
- + Fully Welded - not bolted
- + Interchangeable SS front panel

- + 360 S/S Fixings
- + Australian Made
- + Vandal resistant
- + Watermark-certified

OPTIONS

- + Tap and Dog Bowl
- + Catchment Tray
- + Drinking Bubbler
- + surface mounted tap
- + Carbon Filter
- + Anti graffiti coating
- + Artwork - logo/plaque/vinyl wrap

DIMENSIONS

- + Total Height: 1050mm
- + Width: 180mm x 250 mm



+ BF200 Standard



+ BF200 Bottle refill with tap and dog bowl



+ BF200 with optional Catchment tray



+ BF200 with optional bubbler

DRINKING FOUNTAIN + REFILL STATIONS

Drinking Fountain Solutions

+ STANDARD POST BUBBLER

FEATURES

- + Bubbler
- + RHS Steel Construction
- + 316 S/S Fixings

DIMENSIONS

- + Total Height: 1000mm
- + Width: 100mm Dog bowl
- + Height: 170mm

- + Watermark Certified
- + Surface Mounted
- + Australian Made
- + Vandal resistant

OPTIONS

- + Bottle Filler
- + Maintenance Tap
- + Full Stainless Steel Body Finish
- + Tap Protector Shrouds
- + Leash Handles
- + Inground Fixings



+ SPB Standard



+ SPB with bottle filler and maintenance tap.



+ SPB with bubbler in full Stainless Steel body.



DRINKING FOUNTAIN + REFILL STATIONS

Drinking Fountain Solutions

+ CF400

FEATURES

- + Stainless Steel Modular Construction
- + 3 x Bottle Filler
- + 3 x Drinking Bubblers
- + 316 S/S Trough and Fixings
- + Water Filter

DIMENSIONS

- + Total Height: 951mm
- + Width: 1624mm
- + Depth: 497mm

- + 240V Electrical supply
- + Australian Made
- + Vandal resistant
- + Wall mounted (height can vary to suit requirements)
- + Easy Installation
- + 72 L/hour chilling capacity
- + Easy Activated push buttons
- + Water Filter

OPTIONS

- + Optional custom signage/artwork
- + Floor Mounted options - bubbler height 715mm
- + Non-Chilled
- + DDA Side Basin
- + Available in over 100+ Dulux Powder Coat Colours

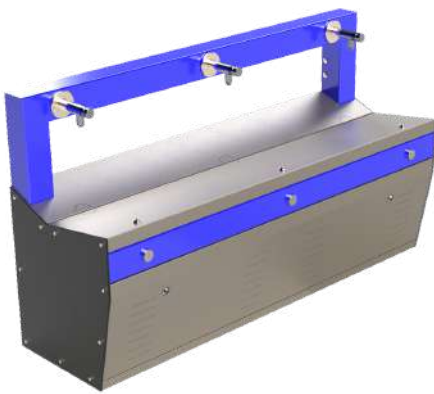

+ CF400 Standard Wall Mounted



+ CF400 Premium Wall Mounted



+ CF400 Premium Wall Mounted with DDA Basin

+ CF430

FEATURES

- + Stainless Steel Modular Construction
- + 3 x Bottle Filler
- + 3 x Drinking Bubblers
- + 316 S/S Trough and Fixings
- + Water Filter

DIMENSIONS

- + Total Height: 951mm
- + Width: 1624mm
- + Depth: 497mm

- + 240V Electrical supply
- + Australian Made
- + Vandal resistant
- + Floor Mounted (bubbler height 907mm)
- + Easy Installation
- + 72 L/hour chilling capacity
- + Easy Activated push buttons

OPTIONS

- + Optional custom signage/artwork
- + Non-Chilled
- + DDA Side Basin
- + Available in over 100+ Dulux Powder Coat Colours



+ CF430 Standard Floor Mounted



+ CF430 Premium Floor Mounted



+ CF430 Premium Floor Mounted with DDA Basin

DRINKING FOUNTAIN + REFILL STATIONS

Drinking Fountain Solutions

+ CF420

FEATURES

- + Stainless Steel Modular Construction
- + 2 x Bottle Filler
- + 2 x Drinking Bubblers
- + 316 S/S Trough and Fixings

DIMENSIONS

- + Total Height: 951mm
- + Width: 1624mm
- + Depth: 497mm

- + 240V Electrical supply
- + Australian Made
- + Vandal resistant
- + Wall mounted (height can vary to suit requirements)
- + Water Filter
- + Easy Installation
- + 72 L/hour chilling capacity
- + Easy Activated push buttons

OPTIONS

- + Optional custom signage/artwork
- + Floor Mounted options
- + Non-Chilled
- + Available in over 100+ Dulux Powder Coat Colours



+ CF420 Standard Wall Mounted



+ CF420 Premium Wall Mounted



+ CF420 Premium Floor Mounted



DRINKING FOUNTAIN + REFILL STATIONS

Drinking Fountain Solutions

+ CF410

FEATURES

- + Stainless Steel Modular Construction
- + 1x Bottle Filler
- + 1x Drinking Bubblers
- + 316 S/S Trough and Fixings
- + Water Filter

DIMENSIONS

- + Total Height: 951mm
- + Width: 1624mm
- + Depth: 497mm

- + Wall Mounted (height can vary to suit requirements)
- + Australian Made
- + Vandal resistant
- + Easy Installation
- + Compressor PW5.5VK, 148W
- + Chilled water flow rate: 19L/ Hr
- + 5L Holding tank (Chilled Water)
- + Easy Activated push buttons

OPTIONS

- + Different Powder coated colour options for button plate
- + Optional Signage or Logo Panel with branding for side panels



+ CF410 Standard Wall Mounted

+ CF200

FEATURES

- + Heavy - duty one piece steel construction
- + Bottle Filler
- + Fully Welded - not bolted
- + 316 S/S Basin and Fixings

DIMENSIONS

- + Total Height: 951mm
- + Width: 1624mm
- + Depth: 497mm

- + Easy Action Button
- + 30 L/hour Chilling Capacity
- + Australian Made
- + Vandal Resistant
- + Concealed Fixings

OPTIONS

- + Tap and Dog Bowl
- + Maintenance Tap
- + Carbon Filter
- + Inground Fixing Cage
- + Anti Graffiti Coating



+ CF200 Standard

+ CF200 with optional tap & dog bowl

DRINKING FOUNTAIN + REFILL STATIONS

Drinking Fountain Solutions

+ SU600

FEATURES

- + 5mm Heavy Duty Steel Body
 - + Hot Dipped Galvanised
 - + Primed & Powder Coated
 - + 316 S/S Basin & Fixings
 - + Sand Resistant Button
- + Vandal Resistant
 - + WaterMark Certified
 - + Australian Made

OPTIONS

- + Tap and Dog Bowl
- + Maintenance Tap
- + Carbon Filter
- + Anti Graffiti Coating

DIMENSIONS

- + Total Height: 962mm
- + Diameter: 280mm



DRINKING FOUNTAIN + REFILL STATIONS

Drinking Fountain Solutions

+ PF400 & PF450

FEATURES

- + RHS Steel Construction
- + 360 S/S Fixings
- + Australian Made
- + Vandal resistant
- + Watermark-certified
- + Surface Mounted
- + Vandal resistant

OPTIONS

- + Bottle Filler
- + Maintenance Tap
- + Full stainless Steel Body Finish
- + Tap Protector Shrouds
- + Leash Handles
- + Inground fixings

DIMENSIONS

- + Total Height: 1000mm
- + Width: 100mm Dog bowl
- + height: 170mm



+ PF400 Standard



+ PF400 with optional bottle filler



+ PF450 Standard



+ PF450 with optional side panel artwork

+ DOG STATION – BAG DISPENSER AND DOG BOWL

FEATURES

- + RHS Steel Construction
- + 316 S/S Fixings
- + Australian Made
- + Vandal resistant
- + Watermark-certified
- + Surface Mounted

OPTIONS

- + Bottle filler
- + Maintenance tap
- + Full Stainless Steel Body Finish
- + Tap Protector Shrouds
- + Leash Handles
- + Inground fixings

DIMENSIONS

- + Total Height: 1000mm
- + Width: 100mm Dog bowl
- + Height: 170mm



+ PF400 Dog station or BF400 Dog station with dog waste dispenser and Tap and dog bowl

URBAN+ DRINKING FOUNTAIN

Drinking Fountain Solutions

POPULAR COLORS:



COAST



STORM



LEAF



EVERGREEN



DESERT



FLAME



MONUMENT



SILVER

Visit the Urban+ Website to access the Dulux colour chart (over 100 options)



+ BRANDED FOUNTAINS

URBAN+ HAVE THE CAPABILITY TO CUSTOM BRAND A RANGE OF FOUNTAINS

SOME OF OUR BRANDABLE PRODUCTS:

- + A280 Architectural Fountain
- + PF450 Pet Fountain
- + BF200WM Bottle Refill Strip
- + BF200 Floor Mounted Bottle Refill Station

Branding options include a one colour or multi-colour decal sticker or aluminium plaque with acid-etched logo/wording.

SEATS AND DAY BEDS



WHY CHOOSE URBAN SEATS AND DAY BEDS

- + **Australian Made for Public Environments** – Locally designed and manufactured using durable, commercial-grade materials built to perform in high-use settings.
- + **Versatile Design Range** – From bold, modern silhouettes to relaxed, lounge-style day beds—our collection caters to a wide range of outdoor spaces.
- + **Improves Public Space Experience** – Adds comfort, function, and visual appeal to parks, schools, waterfronts, and community areas.
- + **Customisable to Suit Your Project** – Offered in a range of materials, finishes, and colours to align with your design intent.
- + **Engineered for Longevity** – Resilient in tough outdoor conditions—supported by Urban+ quality, durability, and craftsmanship.

URBAN+ FURNITURE

SEATING

+ APLERTON BENCH SEAT

+ A durable, modern seat made from cast aluminum with timber slats. The Alperston is ergonomically designed for comfort and built for strength and durability.

DIMENSIONS

- + Seat Height: 500mm
- + Length: 1750mm



+ ASTON BENCH SEAT

+ A stylish seating solution for parks, urban areas, or seaside locations. Enhances public spaces and offers a timber-free alternative for low maintenance.

DIMENSIONS

- + Height: 480mm
- + Width: 501mm
- + Length: 1800mm



+ ASTON DOUBLE SEAT

+ A stylish contemporary seating for parks, urban areas, or seaside locations. It enhances public spaces and provides a relaxing spot. Available in various powder-coated colors or recycled plastic battens.

DIMENSIONS

- + Seat Height: 450mm
- + Seat Width: 1112mm
- + Seat Length: 1800mm



+ ASTON STOOL

+ A stylish contemporary seat for parks, urban areas, or seaside locations. Enhances public spaces and provides a relaxing spot. Available in various powder-coated colors, galvanized steel finish, or recycled plastic battens.

DIMENSIONS

- + Seat Height: 480mm
- + Seat Width: 450mm
- + Seat Length: 450mm

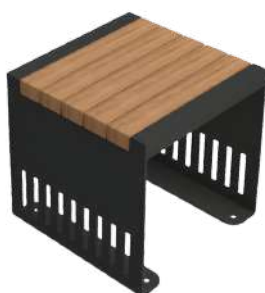

+ BASIC BENCH SEAT

+ A simple steel bench with timber slats, designed for strength and durability. The Basic Bench features high-quality imported Kwila, treated with a triple coated stained timber for enhanced durability and appearance.

DIMENSIONS

- + Seat Height: 460mm
- + Length: 1750mm



+ BCC BENCH SEAT

+ Used by Brisbane City Council in the CBD and suburbs, the BCC Bench Seat features laser-cut steel and timber slats for comfort. Manufactured by Urban+ to BS-7201 standards, it includes a backrest and two armrests for durability.

DIMENSIONS

- + Seat Height: 648mm
- + Standard Length: 1750mm



URBAN+ FURNITURE

SEATING

+ BCC CONCRETE URBAN STOOL

+ These stools are made from dyed concrete for a rich, stable color. A customized lifting point facilitates installation and is concealed by a stainless steel top cap.

DIMENSIONS

- + Width 600mm
- + Height 450mm



+ CITY BENCH SEAT WALL MOUNTED OR STANDARD

+ A durable seat available as wall-mounted or free-standing, perfect for urban areas and parks with restricted footpath access.

DIMENSIONS

- + Seat Height: 500mm
- + Seat Width: 450mm
- + Length: 1600mm



+ SBI BENCH SEAT

+ Made from laser-cut steel with timber slats, the SBI is ergonomically designed for comfort and built for optimal strength and durability.

DIMENSIONS

- + Seat Height: 485mm
- + Seat Length: 1703mm



URBAN+ FURNITURE

SEATING

+ SB3 BENCH SEAT

+ An example of simple, ultramodern design, the SB3 is made from laser-cut steel with 16mm round bars. Ergonomically designed for comfort, it ensures optimal strength and durability.

DIMENSIONS

- + Seat Height: 486mm
- + Seat Length: 1700mm

+ SB5 BENCH SEAT

+ The perfect low-maintenance bench for parks and urban settings, this steel seat is exceptionally strong and built to endure tough climatic and environmental conditions.

DIMENSIONS

- + Height 486mm
- + Length 1750mm
- + Width 536mm

+ TULLY BENCH SEAT

+ A strong, modern bench for schools and parks, available with aluminum, timber, or recycled plastic battens and a variety of powder-coated colors

DIMENSIONS

- + Seat Height: 461mm
- + Seat Width: 376mm
- + Length: 1800mm



URBAN+ FURNITURE

SEATING

+ TULLY SEAT

+ A modern aluminum batten seat for schools and parks, featuring a backrest and two armrests for DDA compliance. Available with timber or recycled plastic battens and various powder-coated colors.

DIMENSIONS

- + Seat Height: 453mm
- + Seat Width: 536mm
- + Length: 1624mm

+ ASTON DAY BED

+ A stylish contemporary daybed perfect for parks, urban areas, or seaside locations. It enhances public spaces and provides a relaxing spot for people

DIMENSIONS

- + Seat Height: 450mm
- + Seat Width: 1697mm
- + Seat Length: 1692mm

+ DB06 DAY BED

+ A strong, functional piece of street furniture that combines the timeless look of timber with polished stainless and powder-coated steel. The bullnose timber edges add a modern distinctive flair.

DIMENSIONS

- + Seat Height: 440mm
- + Seat Width: 1800mm
- + Seat Length: 1800mm
- + Weight: 200kg

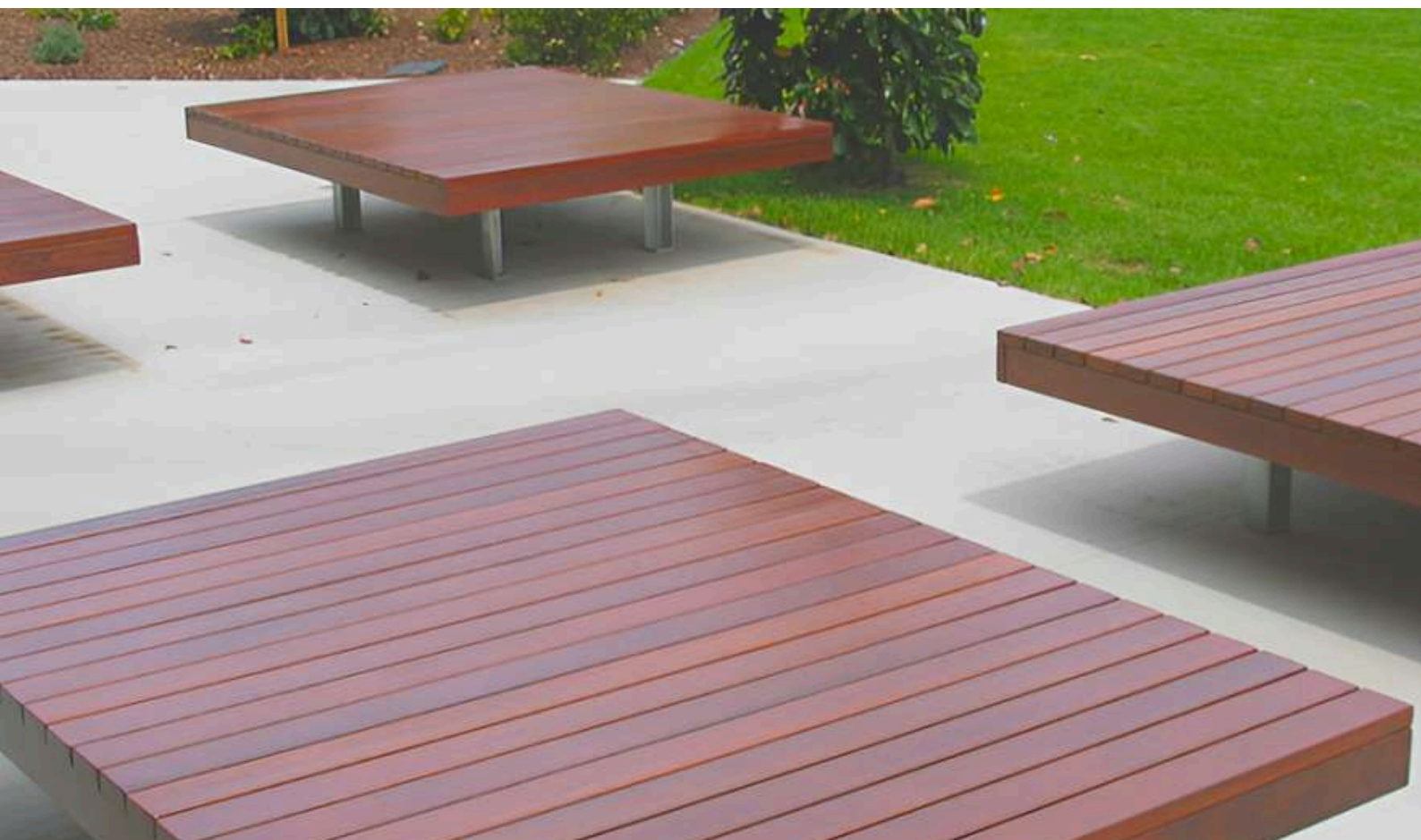

PICNIC TABLE



WHY CHOOSE URBAN PICNIC TABLES

- + **Built for Australian Conditions** – Manufactured locally using commercial-grade materials suited for schools, parks, and coastal environments.
- + **Wide Range of Material Choices** – Available in FSC-certified timber, aluminium, steel, and recycled plastic to suit your sustainability and design goals.
- + **Inclusive and Accessible** – Designed with accessibility in mind, including options that accommodate wheelchair users.
- + **Extensive Colour Selection** – Choose from over 100 Dulux powder-coated finishes to seamlessly match any landscape.
- + **Made to Last** – Crafted to endure harsh weather and heavy use while retaining long-term durability and aesthetic appeal.

URBAN+ FURNITURE

PICNIC TABLE

+ ASTON PICNIC TABLE

+ A modern picnic setting for parks or urban spaces, offering a place to relax. Available in multiple colors or a galvanized steel finish

DIMENSIONS

- + Seat Height: 480mm
- + Seat Width: 450mm
- + Seat Length: 1800mm
- + Table Height: 800mm
- + Table Width: 826mm

+ PT02 PICNIC TABLE

+ A heavy-duty picnic table with separate seating and recessed legs for wheelchair access. Available with timber or aluminum battens.

DIMENSIONS

- + Seat Height: 450mm
- + Length: 2000mm
- + Table Height: 800mm

+ BT01 PICNIC TABLE

+ A durable inground picnic setting with wheelchair access at both ends. Features galvanized steel and triple-coated timber, with optional aluminum or recycled plastic battens.

DIMENSIONS

- + Height: 757mm (above ground)
- + Width: 1800mm
- + Length: 1800mm



URBAN+ FURNITURE

PICNIC TABLE

+ PT03 PICNIC TABLE

+ A sturdy one-piece picnic table for 6, made with triple-coated timber and a galvanized, powder-coated steel frame. Built to withstand Australia's harsh conditions

DIMENSIONS

- + Seat Height: 504mm
- + Length: 1750mm
- + Table Height: 807mm
- + Table Width: 870mm

+ PT06 PICNIC TABLE

+ A Durable picnic table with a classic timber look, polished stainless steel, and powder-coated steel. Unique decorative center panel and bullnose edges.

DIMENSIONS

- + Seat Height: 450mm
- + Length: 1800mm
- + Table Height: 800mm

+ TULLY PICNIC TABLE

+ Durable picnic setting for schools and parks with a 'floating' tabletop and bench. Made from a steel frame and aluminum battens, it's easy to maintain and vandal-resistant.

DIMENSIONS

- + Table Height: 808mm
- + Table Depth: 820mm
- + Seat Height: 461mm
- + Seat Depth: 376mm
- + Length: 1800mm

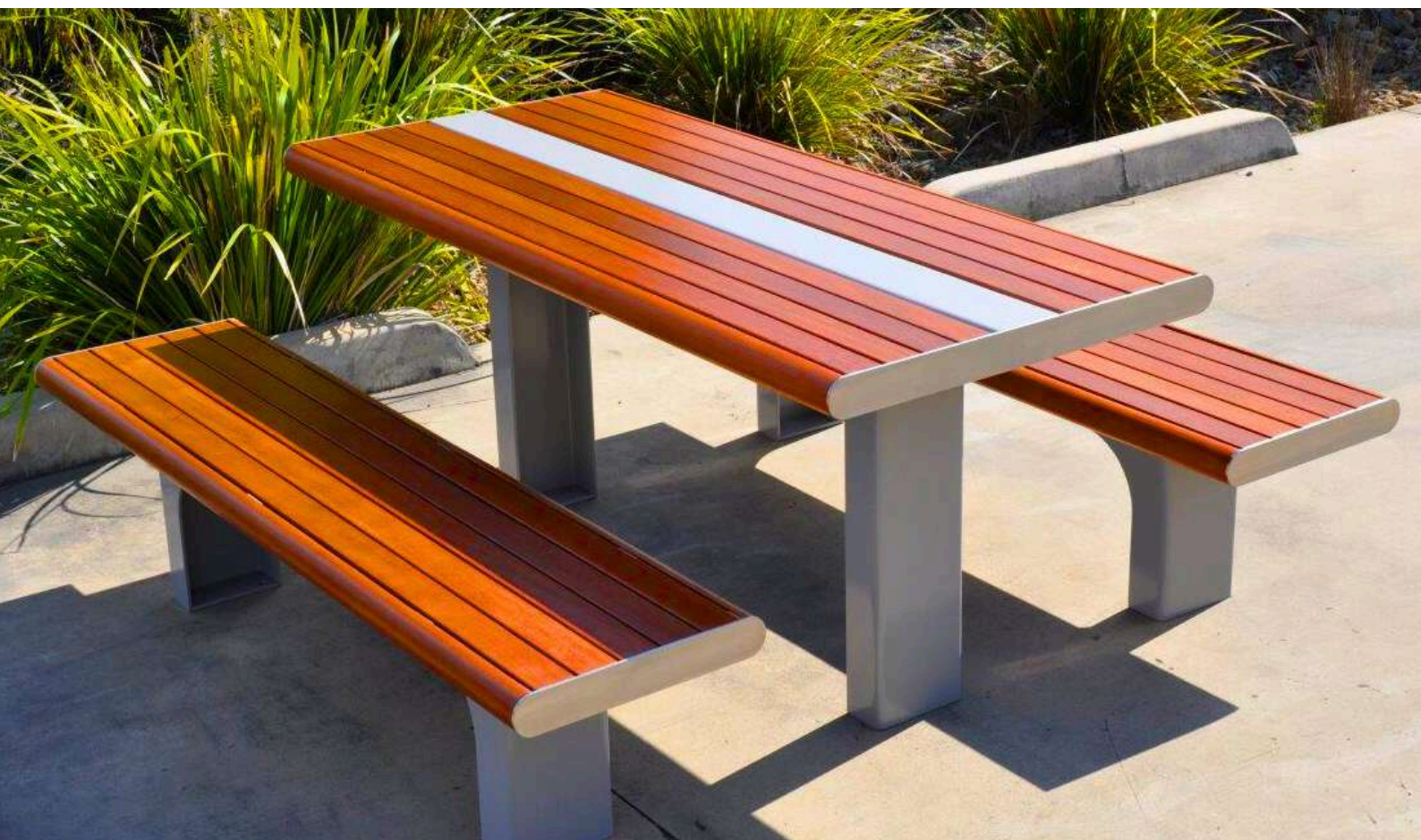

BIKE RACKS



WHY CHOOSE URBAN BIKE RACKS

- + **In-House Design and Manufacturing** - All racks are designed and built by our team in Australia, giving us complete control over quality, lead times, and customisation—something mass-imported alternatives can't offer.
- + **Secure, Practical Solutions** - Engineered for real-world use, our bike racks offer secure parking for single or multiple bikes without compromising space or user accessibility.
- + **Built for Public Environments** - Constructed with heavy-duty, commercial-grade materials that withstand daily wear, vandalism, and the elements—ensuring long-term performance and minimal maintenance.
- + **Designed with Community in Mind** - We go beyond just storage—our racks support healthier, greener cities by promoting cycling and integrating seamlessly into modern streetscapes.

URBAN+ FURNITURE

BIKE RACKS

+ ARMOR SINGLE BIKE RACK

+ A simple, solid bike rack for securing push bikes, available in marine-grade 316 stainless steel or powder-coated finish. This versatile fixture suits various projects and locations

DIMENSIONS

- + Height: 880mm
- + Width: 900mm



+ ASTON MULTI BAY BIKE RACK

+ A stylish, contemporary bike rack ideal for parks, urban areas, or seaside locations. It enhances public spaces by providing a secure fixture for bikes and can be customized with your own laser-cut logo

DIMENSIONS

- + Height: 806mm
- + Width: 500mm
- + Length: 1624mm



+ ASTON SINGLE BIKE RACK

+ A stylish, contemporary bike rack perfect for parks, urban areas, or seaside locations. It enhances public spaces with a secure fixture for bikes and can be customized with your laser-cut logo.

DIMENSIONS

- + Height: 1006mm
- + Depth: 134mm
- + Width: 340mm

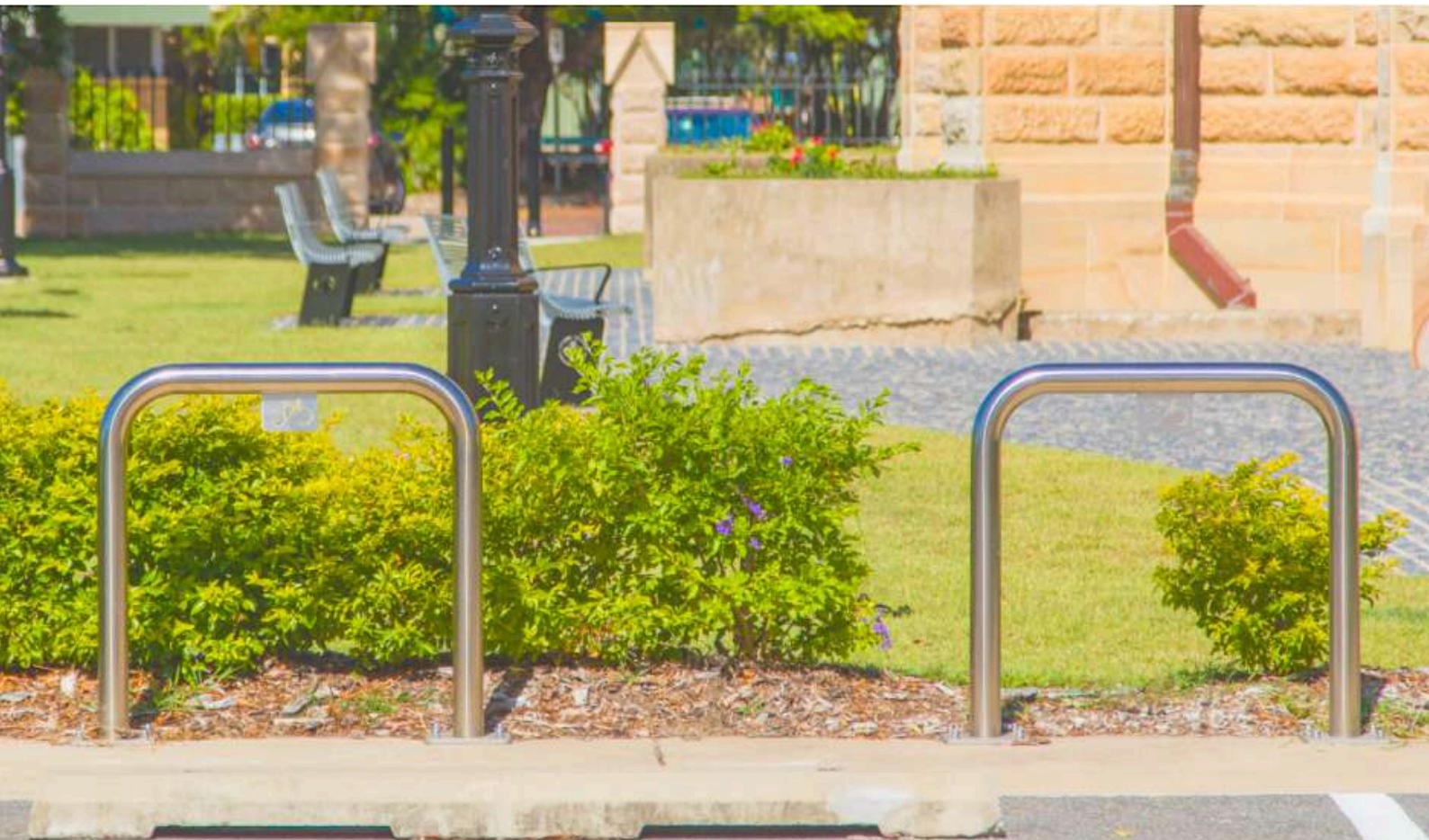

URBAN+ FURNITURE

BIKE RACKS

+ BCC BICYCLE RACKS

+ Available in Single Bay (BSD-5051) and Multi-Bay (BSD-5052) options, these stainless steel bike racks provide a simple, unobtrusive solution for securing push bikes.

DIMENSIONS

- + Single Bay – 800mm x 810mm
- + 3 Bay – 800mm x 963mm
- + 4 Bay – 800mm x 1173mm
- + 5 Bay – 800mm x 1456mm

+ CURVED SINGLE BIKE RACK

+ A solid bike rack for securing push bikes, available in marine-grade 316 stainless steel or powder-coated finish. Versatile for various projects, with options to create a multi-bay setup.

DIMENSIONS

- + Height: 1000mm
- + Width: 748mm

+ TULLY SINGLE BIKE RACK

+ A solid bike rack for schools and parks, available in various powder-coated colors or stainless steel. The laser-cut bike logo clearly indicates its purpose and can be customized for your needs.

DIMENSIONS

- + Height: 986mm
- + Width: 340mm



OUTDOOR SHOWERS

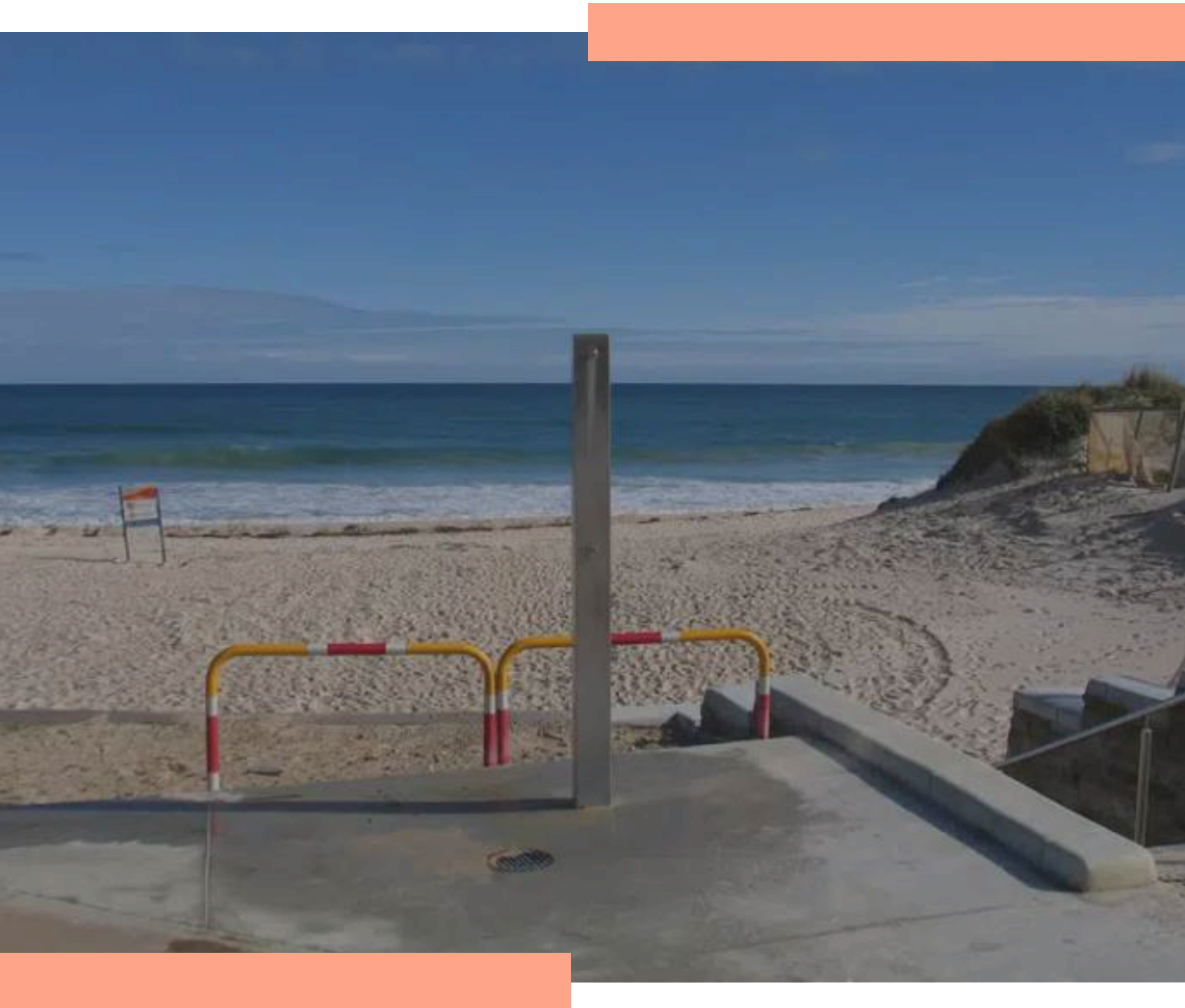

WHY CHOOSE URBAN OUTDOOR SHOWERS

- + **Marine-Grade Durability** - Constructed from high-quality 316 stainless steel for superior corrosion resistance in coastal and outdoor environments.
- + **Built for Tough Conditions** - Engineered to perform in high-use, weather-exposed locations including beaches, pools, and public recreation areas.
- + **Water-Saving Functionality** - Features a timed push-button system to minimise water use and promote sustainable operation.
- + **Stylish and Functional** - Combines clean, modern aesthetics with robust design to enhance both appearance and usability.
- + **Perfect for Coastal Projects** - An ideal fit for resorts, beachfronts, aquatic centres, and anywhere durability meets design.

+ **ECO SHOWER**

+ A uniquely designed triangular outdoor shower, the Eco Shower features a stylish yet simple design that complements any Australian beachfront, public swimming facility, or private resort.

DIMENSIONS

- + Height: 2207mm
- + Width: 155mm



URBAN+ FURNITURE

OUTDOOR SHOWERS

+ SS150 SHOWER

+ It complements any Australian beachfront, public swimming facility, or private resort. Made from 445 and 316 stainless steel, it withstands harsh coastal conditions and resists corrosion. Available in various powder-coated colors, it blends with the surroundings, and activator buttons are timed to prevent water wastage.

DIMENSIONS

- + Height: 2200mm
- + Width: 162mm



TREE GRATES AND GUARDS

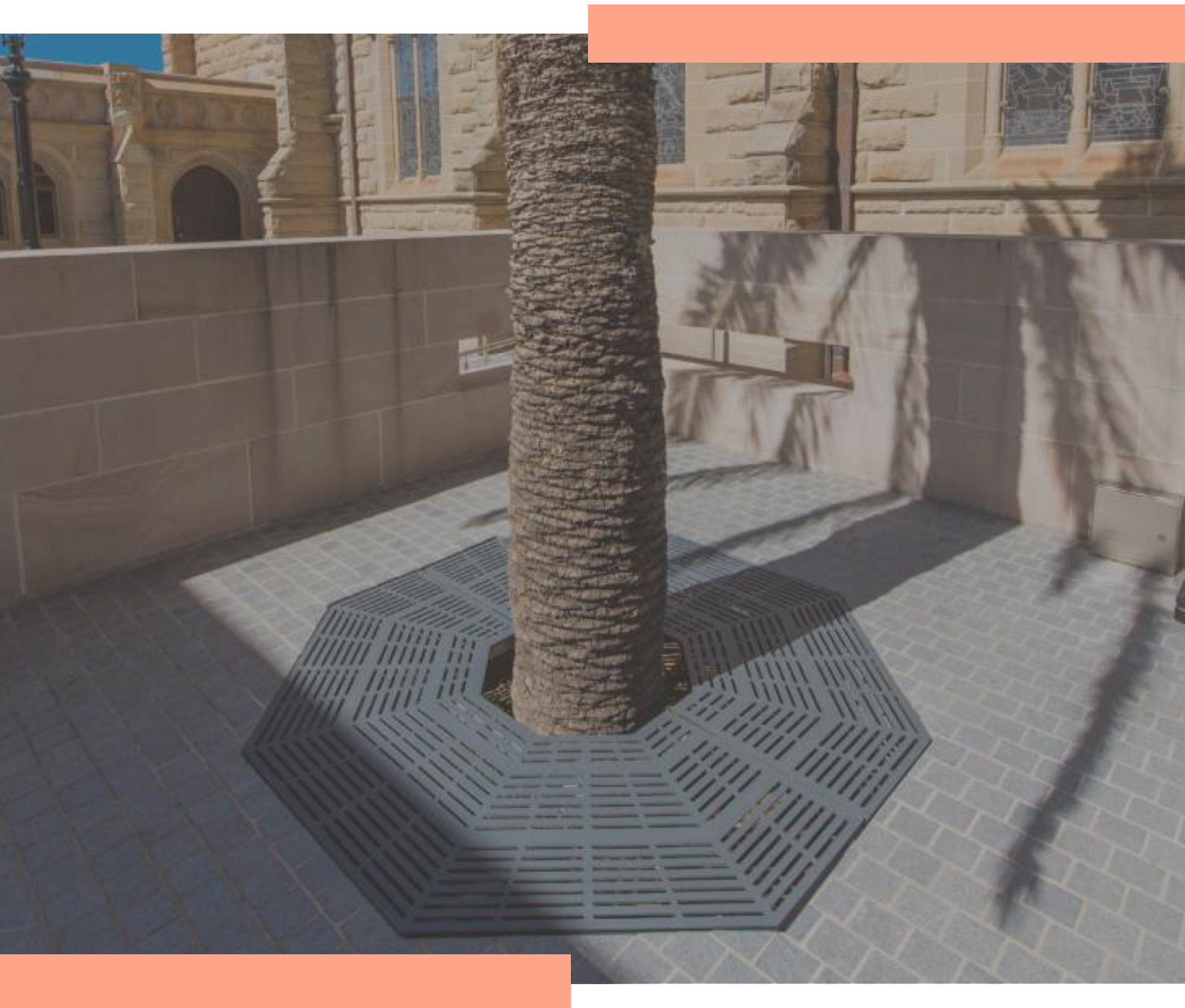

WHY CHOOSE URBAN TREE GRATES/GUARDS

- + **Superior Strength and Longevity** – Built tougher than standard aluminium options—ideal for high-traffic, high-impact environments.
- + **Customisable** – Made to order with tailored sizing, patterns, load ratings and shapes to suit your project requirements.
- + **Australian Made, Quality Assured** – Designed and manufactured locally for consistent quality, reliability, and faster lead times.
- + **Precision Laser-Cut Design** – Combines structural integrity with detailed aesthetics to enhance streetscapes and landscapes.
- + **Optional Frame Systems** – Matching tree grate frames available to support correct installation and long-term durability.

URBAN+ FURNITURE

TREE GRATES

+ BCC TREE GRATES

+ We offer standard decorative tree grates for new trees and custom load-rated grates for existing ones. Urban also makes custom grates for upright fittings and matching frames for BCC tree grates.

DIMENSIONS

- + Standard Grate Sizes: 1600mm x 1600mm and 1200mm x 1600mm (BSD-9071)
- + Center Cut Out 380mm diameter
- + Standard Frame Sizes: 1600mm x 1600mm and 1200mm x 1600mm

+ DECORATIVE TREE GRATES & FRAMES

+ A range of round tree grates and frames for the landscape industry, made from strong laser-cut steel, offering superior durability compared to aluminum grates on the market.

DIMENSIONS

- + Standard Frame Sizes: 1200mm or 1600mm
- + Standard Centre Cut Out 380mm diameter

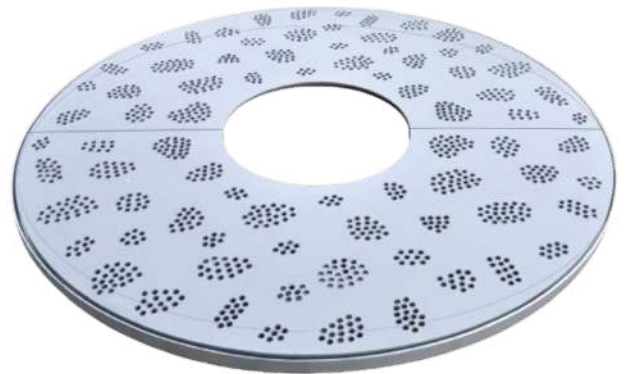

URBAN+ FURNITURE

TREE GRATES

+ LOAD RATED GRATES AND FRAMES

+Laser-cut steel tree grates and surrounds provide superior strength and practicality compared to aluminum. Available in standard sizes and patterns, with custom options available.

DIMENSIONS

- + Standard Frame sizes: FR12x12, FR12x16, FR16x16, FRCUSTOM
- + Standard Centre cut out 380mm diameter

+ CLASS A LOAD RATING

Typical Use: Areas (including footways) accessible ONLY to pedestrians & pedal cyclists & closed to other traffic (extra light duty)

+ CLASS C LOAD RATING

Typical Use: Malls and areas open to slow moving commercial vehicles (medium duty)

+ CLASS B LOAD RATING

Typical Use: Areas (including footways & light tractor paths) accessible to vehicles (EXCLUDING commercial vehicles) or livestock (light duty)

+ CLASS D LOAD RATING

Typical Use: Carriageways or roads and areas open to commercial vehicles (heavy duty)

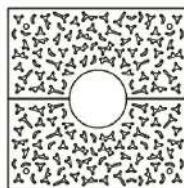

TG 1

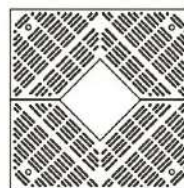

TG 2

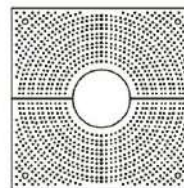

TG 3

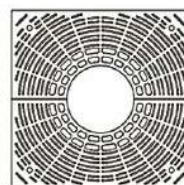

TG 4

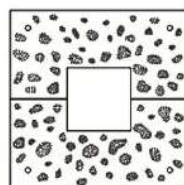

TG 5

- + Standard and custom sizes
- + Suitable for new or existing trees
- + Laser cut steel plate
- + Solid welded construction
- + Optional anti-slip finish



BOLLARDS AND BALUSTRADING

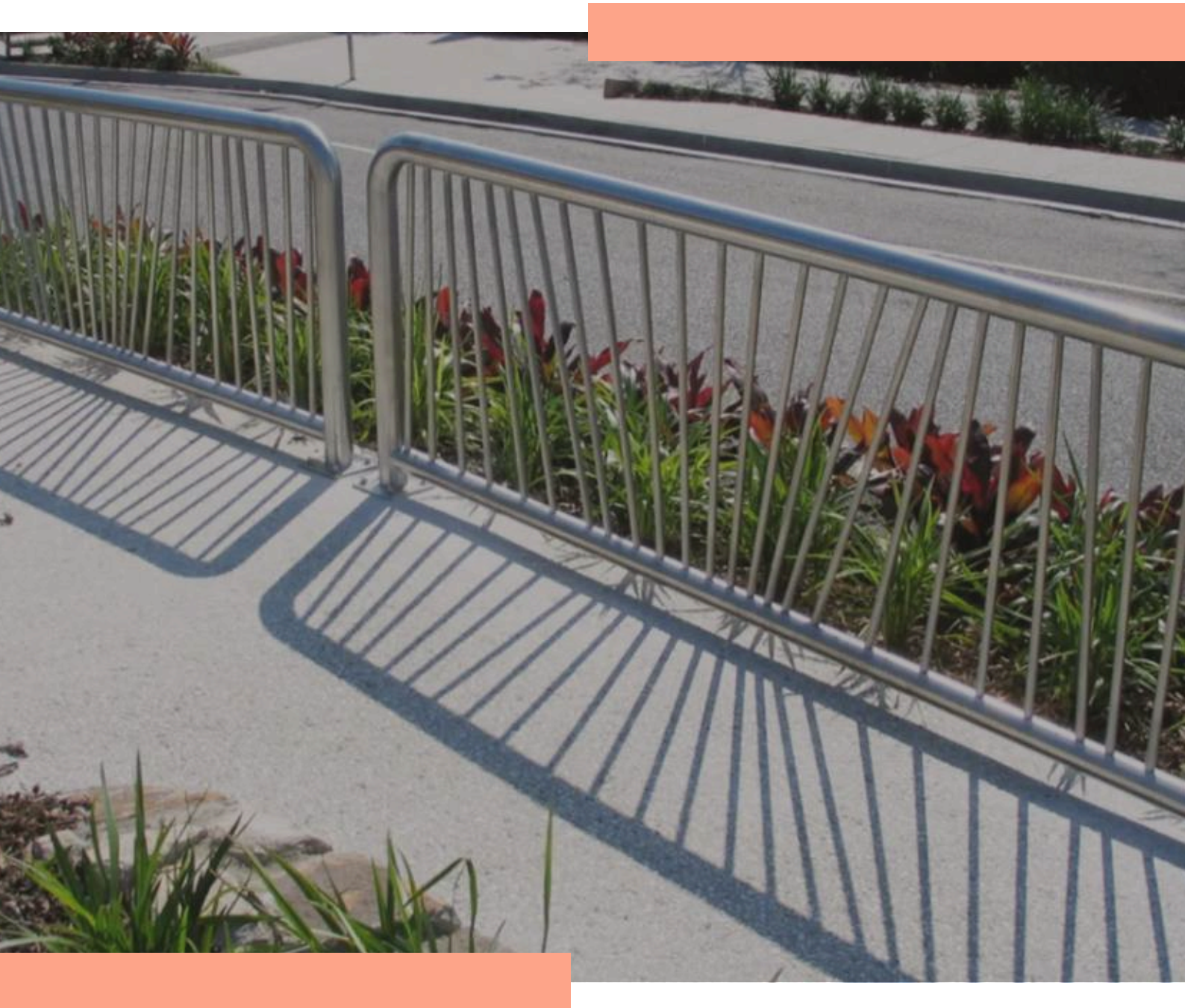

WHY CHOOSE URBAN BOLLARDS AND BALUSTRADING

- + **Engineered for Tough Public Use** – Our bollards are built from heavy-duty, commercial-grade materials that outperform standard options in strength, longevity, and resistance to wear.
- + **Designed and Manufactured In-House** – Unlike many imported alternatives, Urban bollards are made right here in Australia—ensuring full quality control, faster lead times, and local support.
- + **Smart, Secure Design** – Our bollards don't just look good—they're purpose-built to protect people, infrastructure, and assets in demanding environments.
- + **A Seamless Fit for Any Setting** – From modern streetscapes to landscaped parks, our designs integrate effortlessly into public spaces while delivering superior performance over time.

URBAN+ FURNITURE

BOLLARDS + BALUSTRADING

+ BCC BOLLARD

+ Are made as per BCC Specifications. BSD-7096 for removable bollards and BSD-7095 for fixed bollards.

DIMENSIONS

- + Height > 1000mm (plus inground)
- + as per BSD Drawing 7096



+ EDGE BOLLARD

+ A surface-mounted fixture designed to protect people and property. Its unique cut-out design makes it both functional and visually appealing. Available in galvanized steel or powder-coated finish.

DIMENSIONS

- + Height: 880mm
- + Width: 900mm



URBAN+ FURNITURE

BOLLARDS + BALUSTRADING

+ SS24 BALUSTRADING

+ A unique set of stainless steel balustrades for urban streets requiring pedestrian safety, including taxi ranks and suburban centers.

DIMENSIONS

- + Height 1200mm + Length 2400mm
- + 3/4" 304 S/S bars + 76mm diameter
- + 8mm base plate

+ URBAN BOLLARDS + BALUSTRADING

Urban+ is one of Australia's leading suppliers of street and park furniture. Our bollard and balustrading products provide a safe and secure barrier to protect people and property. These street enhancements will suit a variety of landscape projects and will stop unwanted traffic from crossing important boundary lines. Customisation is also available on request.

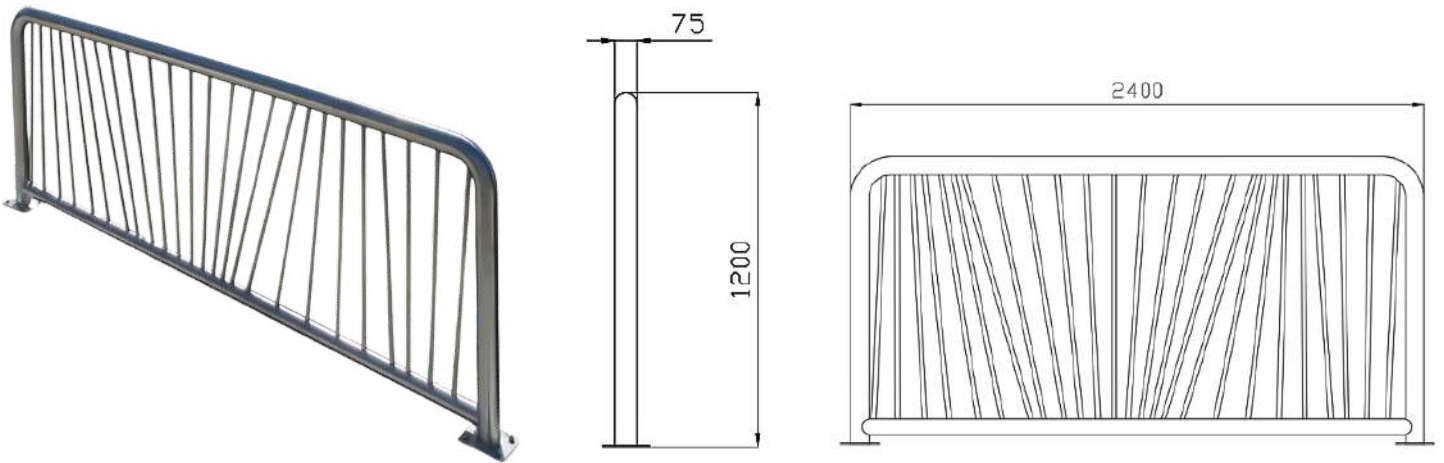

BINS AND ENCLOSURES



WHY CHOOSE URBAN BINS AND ENCLOSURES

- + **Built for High-Demand Public Use** - Commercial-grade construction ensures lasting performance in busy, high-traffic environments.
- + **Flexible Sizing and Configurations** - Available in a range of capacities (70L-240L) to meet diverse waste management needs.
- + **Customisable and Visually Appealing** - Offered in a variety of finishes with optional features like ash trays, signage, and branding for added functionality.
- + **Promotes Cleaner Public Spaces** - Designed to encourage proper waste disposal and reduce litter in urban and community settings.
- + **Durability Meets Design** - Combines robust functionality with contemporary style to complement modern streetscapes

URBAN+ FURNITURE

BINS AND ENCLOSURES

+ ASTON 240L WHEELIE BIN ENCLOSURE

+ Made from 8mm steel plate that is laser cut and folded. It is an extremely strong and robust bin ideal for parks and shopping centres.

DIMENSIONS

- + Height: 1318mm
- + Width: 745mm
- + Depth: 849mm
- + Capacity: 240L

+ ASTON 70L BIN

+ Made from 8mm laser-cut and folded steel plate, robust bin. Choose between timber or aluminum battens, and add an ashtray top if needed.

DIMENSIONS

- + Height: 1056mm
- + Width: 430mm
- + Length: 575mm
- + Capacity: 70L

+ CIVIC 240L WHEELIE BIN ENCLOSURE

+ Stylish yet minimalistic, this robust bin features aluminum construction with oiled Kwila hardwood battens.

DIMENSIONS

- + Height: 1353mm
- + Length: 728mm
- + Depth: 850mm
- + Capacity: 240L

+ CIVIC 90L BIN

+ An aluminum bin with oiled Kwila hardwood battens, designed for strength and durability with minimal maintenance. The powder-coated aluminum frame protects against weather and vandalism.

DIMENSIONS

- + Height: 1060mm
- + Length: 573mm
- + Depth: 430mm
- + Capacity: 90L



URBAN+ FURNITURE

BINS AND ENCLOSURES

+ DOGGIE DUNNIE

+ Designed for clean disposal of compostable dog waste bags. It ensures easy use and contamination-free emptying. Available in various colors and sizes, it's an eco-friendly choice for your project.

DIMENSIONS

- + 55L Capacity
- + 120L Capacity
- + 240L Capacity

+ MANLY DUAL BIN ENCLOSURE

+ A strong, durable surround for two 240L wheelie bins, made from 316 stainless steel and hardwood battens. It features customizable 'Garbage' and 'Recycle' signage. Low-maintenance aluminum battens are also available.

DIMENSIONS

- + Height: 1385mm + Width: 915mm
- + Length: 1580mm + Capacity: 2 x 240L

+ TULLY WHEELIE BIN ENCLOSURE

+ A strong, modern bin made from low-maintenance, vandal-resistant steel and aluminum battens. Available in 120L and 240L sizes with various powder-coated colors, with optional timber and recycled plastic battens.

DIMENSIONS

- + 240L Capacity Option + Height: 1123mm
- + Width: 891mm + Length: 740mm



DOG PARK AGILITY EQUIPMENT

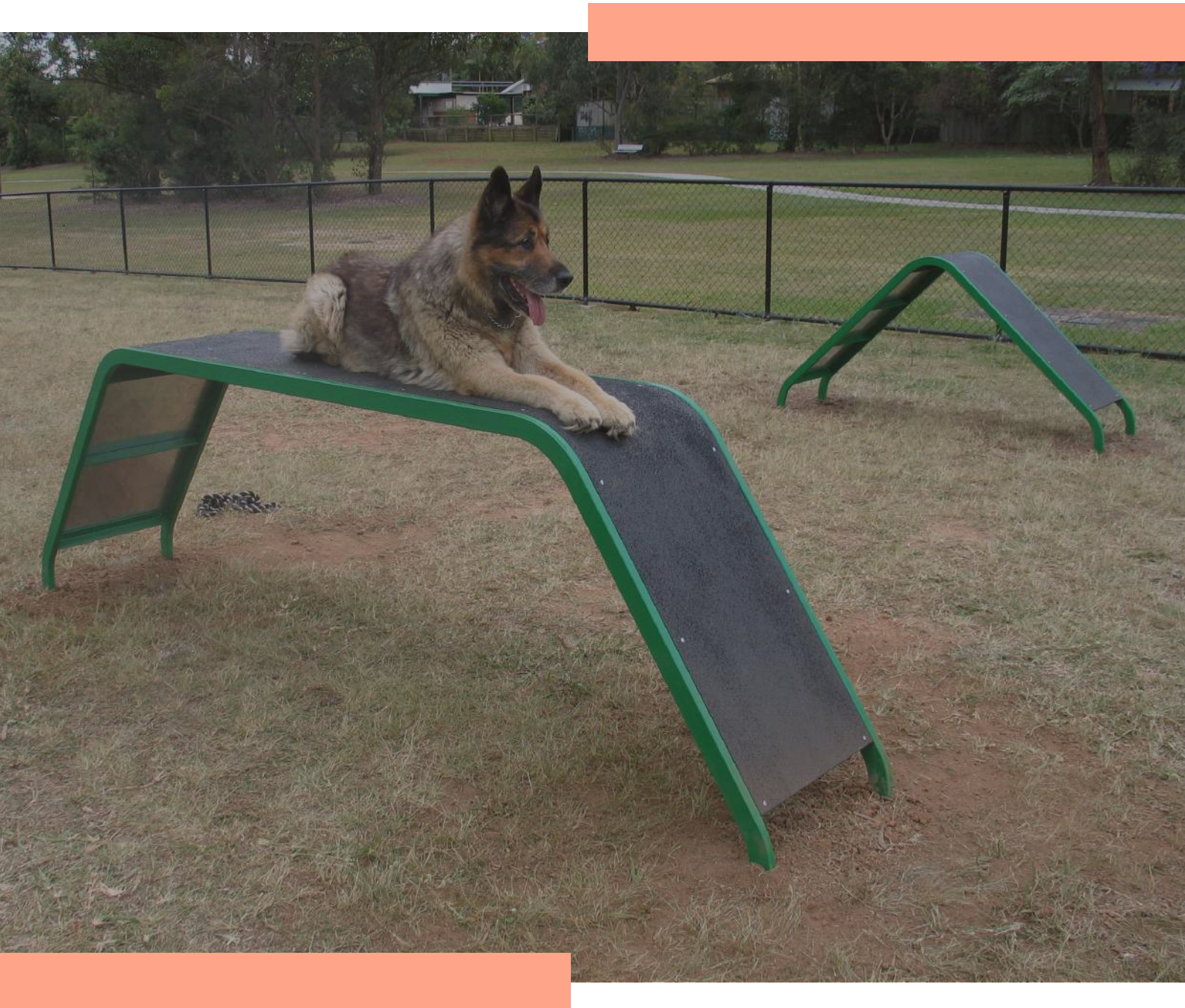

WHY CHOOSE URBAN DOG PARK EQUIPMENT

- + **Engineered for Outdoor Durability** – Constructed from powder-coated galvanised steel for long-lasting performance in off-leash and high-use park environments.
- + **Designed for Engaging Play** – Features a variety of fun and functional elements—like hoops, tunnels, ramps, and jumps—to support both physical activity and mental stimulation.
- + **Backed by Community Value** – Trusted by councils as a meaningful addition to public parks, promoting active lifestyles for dogs and their owners.
- + **Tailored to Your Space** – Available in coordinated colours and layouts to suit your specific dog park or open space design.
- + **Built for Pets, Loved by People** – Combines durability, safety, and playful design to create welcoming, pet-friendly community spaces.

URBAN+ FURNITURE

DOG PARK AGILITY EQUIPMENT

+ DOG DOUBLE BARJUMP

+ Part of Urban+'s dog exercise equipment for off-leash areas in City Council parks, this durable fixture is made from galvanized steel and powder-coated for longevity. Available in various colors or stainless steel, it can be mounted above or below ground.

DIMENSIONS

- + Height: 449mm above ground
- + First bar height: 140mm
- + Width: 1197mm

+ DOG HOOP

+ Part of Urban+'s dog exercise range for off-leash council parks, this durable fixture is made from galvanized steel and powder-coated. Available in various colors or stainless steel, with options for above or below ground mounting.

DIMENSIONS

- + Height: 997mm
- + Width: 795mm
- + 500mm OD Centre hole

+ DOG PODIUM

+ Part of Urban+'s dog agility equipment for off-leash council parks, this durable fixture is made from galvanized steel and powder-coated. Available in various colors or stainless steel, with options for above or below ground mounting.

DIMENSIONS

- + Height: 600mm
- + Width: 480mm
- + Length: 1600mm

+ DOG TUNNEL

+ Part of Urban+'s dog exercise equipment for off-leash council parks, this durable fixture is made from galvanized steel and powder-coated. It comes in various colors or stainless steel, with options for above or below ground mounting

DIMENSIONS

- + Height: 723mm
- + Width: 750mm
- + Length: 1520mm



URBAN+ FURNITURE

DOG PARK AGILITY EQUIPMENT

+ DOG SINGLE BAR JUMP

+ Part of Urban+'s dog exercise range for off-leash council parks, this durable equipment is made from galvanized steel and powder-coated. It is available in various colors or stainless steel, with options for above or below ground mounting.

DIMENSIONS

- + Height: 309mm above ground
- + Width: 1197mm

+ PYRAMID RAMP

+ Part of Urban+'s dog exercise equipment for off-leash council parks, this durable fixture is made from galvanized steel and powder-coated. It comes in various colors or stainless steel, with options for above or below ground mounting.

DIMENSIONS

- + Height: 975mm
- + Width: 495mm
- + Length: 2000mm

+ TABLE DOG RAMP

+ Is part of Urban+'s dog agility equipment for off-leash Council parks, is made from galvanized steel and powder-coated for durability. Available in various colors or stainless steel, with above or below ground mounting options.

DIMENSIONS

- + Height: 872mm
- + Width: 495mm
- + Length: 3126mm

+ DOG WEAVES POLES

+ Is part of Urban+'s dog agility equipment for off-leash Council parks, are made from galvanized steel and powder-coated for durability. Available in various colors or stainless steel, with above or below ground mounting options.

DIMENSIONS

- + Height: 1023mm above ground
- + 60 OD pipe



URBAN FOUNTAINS & FURNITURE

Making Life Better

RESTORATION PROGRAM

CONSERVATION COMMITMENT

+ HELP US REDUCE WASTE BY INCREASING DRINKING FOUNTAIN USE & DRIVING WATER CONSERVATION

Our restoration program allows Urban+ drinking fountain owners to restore their fountain to 'like' new once the outdoors have taken their toll. Our goal is to stop the behaviour to always replace with new and keep Urban+ products and materials in use.



A FEW CLIENTS & PROJECTS



Royal Flying Doctor Service



Brisbane
City Council



THE UNIVERSITY
OF QUEENSLAND
AUSTRALIA



CITY OF
GOLDCOAST.



VANDALISM PROTECTION & WARRANTY

Urban has been making drinking fountains for over 20 years, specialising in products designed to withstand all weather conditions and heavy foot traffic. We are experienced in creating fountains for areas prone to high levels of vandalism. While no design can entirely prevent a determined vandal from causing damage, Urban is confident that our designs significantly reduce the likelihood of any serious or lasting harm.

Key Features to Prevent Vandalism:

- + Material Thickness:** We use the thickest materials possible while maintaining aesthetic appeal to ensure robustness.
- + Secure Tapware:** All custom-designed tapware is encased in additional mounting collars that are fully fillet-welded internally, making it resistant to attempts to remove the taps forcibly. Reinforced stainless steel bars are incorporated to prevent intentional damage and breakage.
- + Hidden Fixings:** We minimise visible external screws, with most fixings hidden internally. Any external fixings use security screws to deter unauthorised tampering.

Warranty

All our fountains are designed and manufactured in Australia, reflecting our commitment to quality and exemplary customer service. We are available to assist with installation inquiries, after-sales support, or replacement parts if needed.

Our fountains are built to last with rigorous quality control measures, including water testing each unit before dispatch. Most plumbing fittings are standard and readily available at plumbing stores, and Urban Valves and bottle fillers can be sourced directly from our factory.

We offer a standard 3-year warranty on all manufactured and plumbing parts, with a lifespan expectancy of over 15 years for our fountains.

ABOUT URBAN+ FOUNTAINS & FURNITURE

+ COMPANY HISTORY

- + Urban+ was founded in 2001 by Husband and Wife team, Gary & Claire Allan, when they saw the opportunity to craft street and park furniture products that would stand the test of time
- + Urban+ operated for 18 years on respect, reputation, and strong working relationship
- + In 2019 Simon Higgins was brought on as a business partner and helped define Urban+'s purpose to support the shift to a circular economy
- + Urban+ now implement circular thinking into all business functions and manufacturing processes, helping to pave the way for Australian manufacturing to become a truly sustainable industry

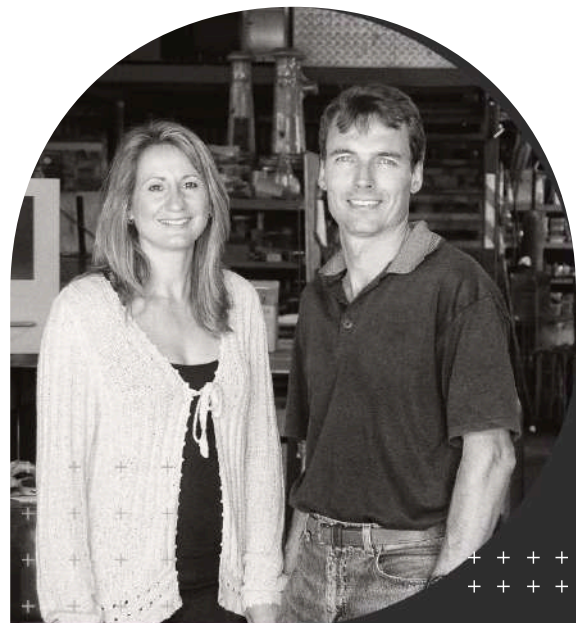

CONTACT URBAN+

Please Note: The products featured in this brochure represent only a part of our extensive range. To explore our full collection of drinking fountains, bottle refill stations, and outdoor furniture solutions, please visit our website by scanning the QR code.



(07) 3382 7372



office@urbanff.com.au



5 Telford Circuit, Yatala, QLD



www.urbanff.com.au





“Good design should serve people, last generations, and tread lightly on the planet – that’s the Urban+ way.”

– urban₊

urban +