

# ENHANCING EDUCATIONAL SPACES

2026

urban+



**MAKING LIFE BETTER**

*urban fountains and furniture*

## CF400 CATALOGUE

[www.schools.urbanff.com.au](http://www.schools.urbanff.com.au)

**urban** +  
for schools

# INDEX

|   | <b>PAGE</b> |
|---|-------------|
| <b>+ PRODUCT DESIGN ETHOS AND KEY SELLING POINTS</b>              | 1           |
| <b>+ CF400 WALL MOUNTED OPTIONS</b>                               | 2-5         |
| <b>+ CF400 FLOOR MOUNTED OPTIONS</b>                              | 6           |
| <b>+ FLOOR MOUNTED OPTIONS IDEAL FOR JUNIORS &amp; KINDY</b>      | 6-9         |
| <b>+ FLOOR MOUNTED OPTIONS IDEAL FOR SENIORS AND SPORTS CLUBS</b> | 10-13       |
| <b>+ CF400 COMPACT OPTIONS</b>                                    | 14          |
| <b>+ WALL MOUNTED COMPACT OPTIONS</b>                             | 16-17       |
| <b>+ FLOOR MOUNTED COMPACT OPTIONS</b>                            | 18-19       |
| <b>+ CHILLER UNIT</b>   | 20          |
| <b>+ LASER-ETCHED SIGNS</b>                                       | 21          |
| <b>+ FREQUENTLY ASK QUESTIONS</b>                                 | 22          |
| <b>+ GENERAL</b>  | 22          |
| <b>+ FEATURES AND OPTIONS</b>                                     | 23          |
| <b>+ PLUMBING</b>   | 24          |
| <b>+ INSTALLATION</b>   | 25          |
| <b>+ MAINTENANCE</b>  | 26          |
| <b>+ VANDALISM PROTECTION WARRANTY</b>                            | 27          |
| <b>+ THE CIRCULAR ECONOMY</b>                                     | 28          |
| <b>+ CONTACT US</b>   | 29          |

# URBAN FOUNTAINS & FURNITURE

Making Life Better

## PRODUCT DESIGN ETHOS

- + Our material choices and product design features are focused on ensuring the longevity and sustainability of each product.
- + We prioritise craftsmanship over mass-produced, machine-made parts and choose to handcraft where it enhances and improves the product.
- + The product design process carefully balances the demands of manufacturing and fabrication with consumer expectations for functionality and aesthetics.
- + Our seamless design approach ensures that what's hidden is just as important as what's visible, and we do not compromise on areas that aren't immediately seen.
- + Our products are built for strength and durability, with no built-in obsolescence, and come with a guarantee for long lasting performance.
- + We use anti-vandal materials, design features, and manufacturing methods to protect against vandalism.



## KEY SELLING POINTS

### + PRODUCT FEATURES

- + Australian-made. All products are manufactured locally in our facility based in Yatala, QLD and are distributed nationally.
- + All drinking fountains are Watermark-certified
- + ISO Quality Management System certified
- + Vandal resistant
- + Disabled accessible options
- + Product branding options
- + Choose from Dulux's full powder coat colour range
- + Customisation of standard products allowed
- + Full custom design service available
- + Service, Maintenance and Refurbishment services offered
- + Product leasing opportunity



Australian Made



Sustainably Made



# CF400 WALL MOUNTED OPTIONS

Ideal for Junior and Seniors



# WHY CHOOSE WALL MOUNTED?

- + Mounting height can be adjusted to meet various user needs, including DDA compliance.
- + Water and drainage lines can be concealed within the wall for a cleaner appearance and reduced clutter.
- + A structural wall will be required for proper installation and support.
- + Wall-mounted fountains generally require fewer materials and simpler construction, translating to a lower overall price tag than comparable floor-mounted models.
- + One key benefit of the CF400 wall-mounted unit is that, without a floor base, it allows for easier cleaning of the surrounding floor area.

# CF400 PRODUCT CATALOGUE

## Wall Mounted

### + CF400 Standard Wall Mounted

#### FEATURES

- + Chiller Unit - 72 L/hour chilling capacity
- + Includes filter for improved water quality
- + Stainless Steel Modular Construction
- + 3 x Bottle Filler
- + 3 x Drinking Bubblers
- + 316 S/S Trough and Fixings
- + Easy Activated push buttons
- + Wall Mounted (height can vary to suit requirements)
- + 240V Electrical supply
- + Australian Made
- + Vandal resistant
- + Easy Installation

#### OPTIONS

- + Over 100 Powder Coating options
- + Non-Chilled.

#### DIMENSIONS

- + Total Height: 900mm
- + Width: 1625mm
- + Depth: 497mm

+ SKU DF\_CF400

BRAND  
ME

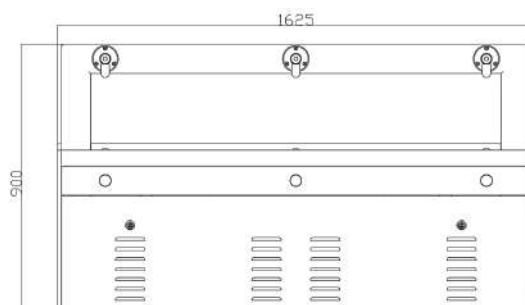
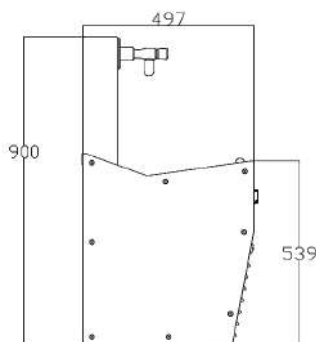
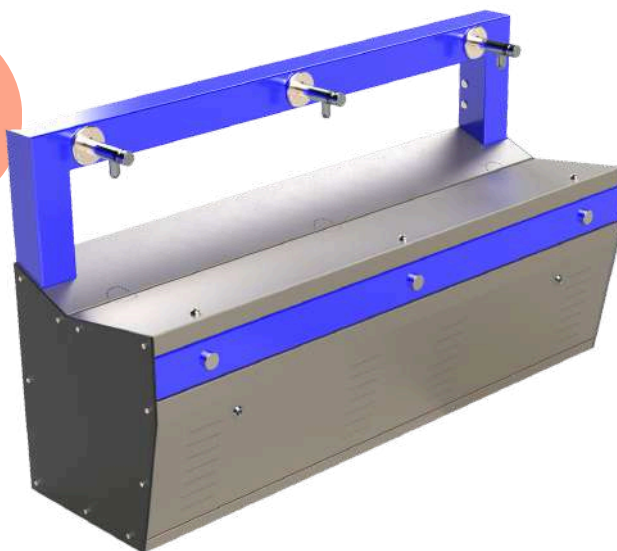

### + CF400 Premium Wall Mounted

#### FEATURES

- + Chiller Unit - 72 L/hour chilling capacity
- + Includes filter for improved water quality
- + Stainless Steel Modular Construction
- + 3 x Bottle Filler
- + 3 x Drinking Bubblers
- + 316 S/S Trough and Fixings
- + Easy Activated push buttons
- + Wall Mounted (height can vary to suit requirements)
- + 240V Electrical supply
- + Australian Made
- + Vandal resistant
- + Easy Installation
- + Signage or logo panel with branding

#### OPTIONS

- + Over 100 Powder Coating options
- + Non-Chilled.

#### DIMENSIONS

- + Total Height: 900mm
- + Width: 1625mm
- + Depth: 497mm

+ SKU DF\_CF400\_P

Laser- Etched  
Sign

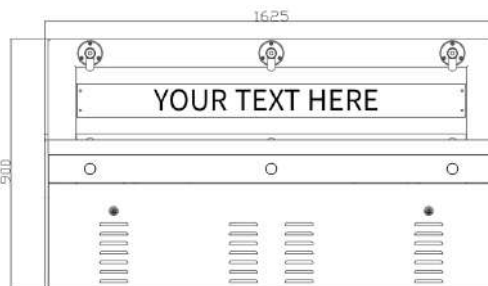
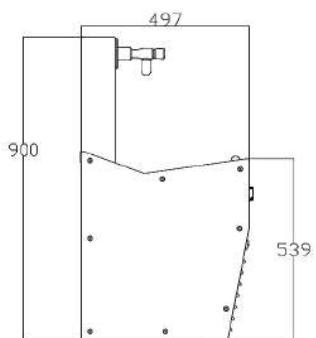
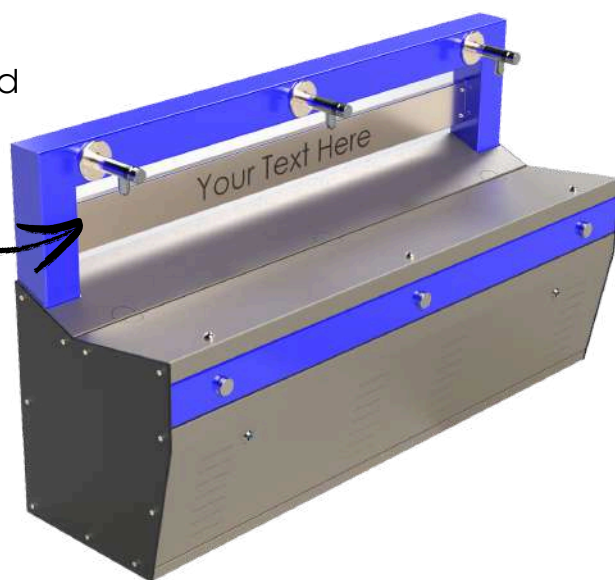
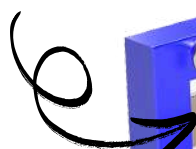

# CF400 PRODUCT CATALOGUE

## Wall Mounted

### + CF400 Standard Wall Mounted with DDA Basin

#### FEATURES

- + Chiller Unit - 72 L/hour chilling capacity
- + Includes filter for improved water quality
- + Stainless Steel Modular Construction
- + 3 x Bottle Filler
- + 3 x Drinking Bubblers
- + 316 S/S Trough and Fixings
- + Easy Activated push buttons
- + Wall Mounted (height can vary to suit requirements)
- + 240V Electrical supply
- + Australian Made
- + Vandal resistant
- + Easy Installation
- + DDA Basin

#### OPTIONS

- + Over 100 Powder Coating options
- + Non-Chilled.

#### DIMENSIONS

- + Total Height: 900mm
- + Width: 2087mm
- + Depth: 591mm

+ SKU DF\_CF400\_BL

BRAND  
ME

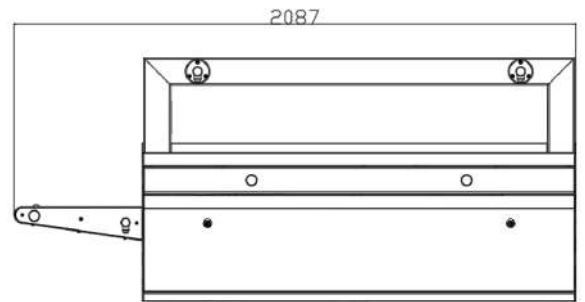
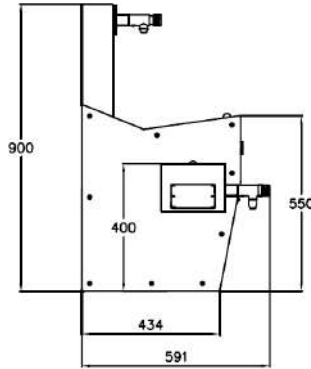
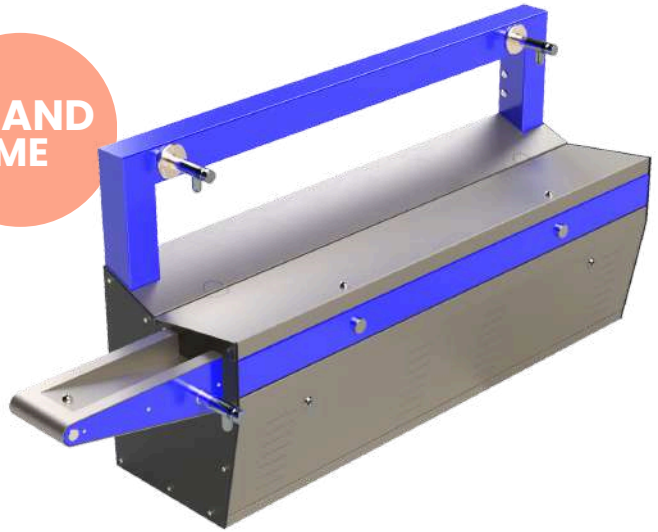

### + CF400 Premium Wall Mounted with DDA Basin

#### FEATURES

- + Chiller Unit - 72 L/hour chilling capacity
- + Includes filter for improved water quality
- + Stainless Steel Modular Construction
- + 3 x Bottle Filler
- + 3 x Drinking Bubblers
- + 316 S/S Trough and Fixings
- + Easy Activated push buttons
- + Wall Mounted (height can vary to suit requirements)
- + 240V Electrical supply
- + Australian Made
- + Vandal resistant
- + Easy Installation
- + Signage or logo panel with branding
- + DDA Basin

#### OPTIONS

- + Over 100 Powder Coating options
- + Non-Chilled.

#### DIMENSIONS

- + Total Height: 900mm
- + Width: 2087mm
- + Depth: 591mm

+ SKU DF\_CF400\_P\_BL

Laser- Etched  
Sign

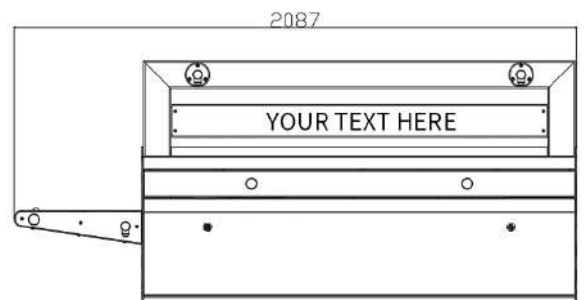
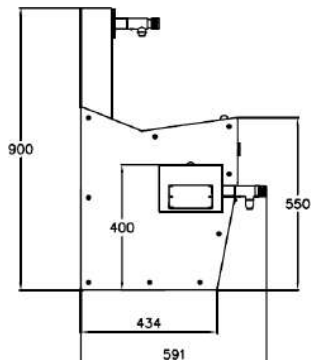
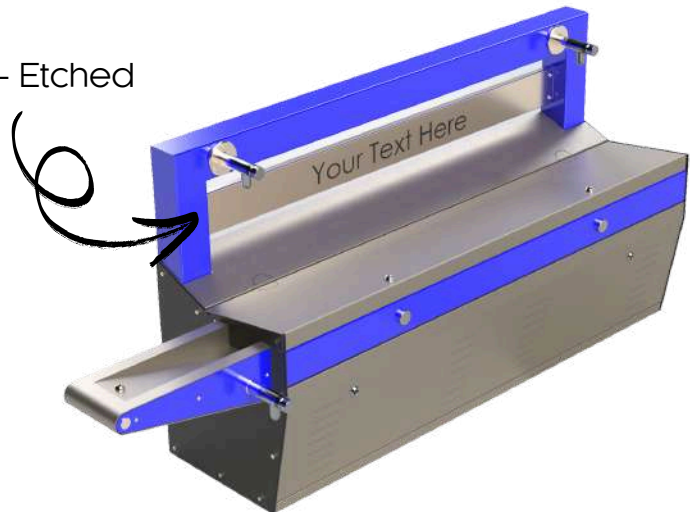

# CF400 FLOOR MOUNTED OPTIONS

Ideal for Juniors & Kindy



# WHY CHOOSE FLOOR MOUNTED?

The CF400 floor-mounted version designed for junior schools, positioning the bubbler at a height of 715 mm. This lower height ensures younger children can comfortably reach bubblers and bottle fillers, encouraging independent hydration and safe use.

- + Floor-mounted units transfer weight directly to the floor, making them ideal for buildings with walls that aren't designed to support heavy wall-mounted fountains.
- + With floor-mounted units, extensive wall cutouts and reinforcements are unnecessary, making installation simpler and less invasive.
- + When facility layouts change, floor-mounted units can be removed and relocated with ease.

# CF400 PRODUCT CATALOGUE

## Floor Mounted

### + CF400 Standard Floor Mounted - Bubbler Height 715mm

#### FEATURES

- + Chiller Unit - 72 L/hour chilling capacity
- + Includes filter for improved water quality
- + Stainless Steel Modular Construction
- + 3 x Bottle Filler
- + 3 x Drinking Bubblers
- + 316 S/S Trough and Fixings
- + Easy Activated push buttons
- + Floor Mounted (approx. bubbler height at 715mm)
- + 240V Electrical supply
- + Australian Made
- + Vandal resistant
- + Easy Installation

#### OPTIONS

- + Over 100 Powder Coating options
- + Non-Chilled.

#### DIMENSIONS

- + Total Height Approx : 1057mm
- + Width: 1625mm
- + Depth: 497mm

+ SKU DF\_CF400\_SM

BRAND  
ME

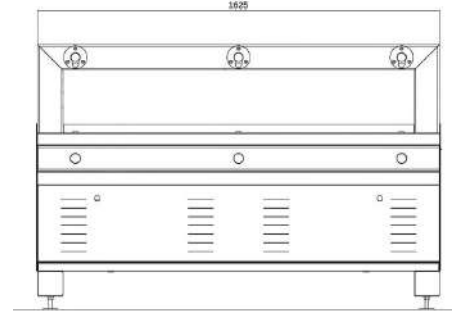
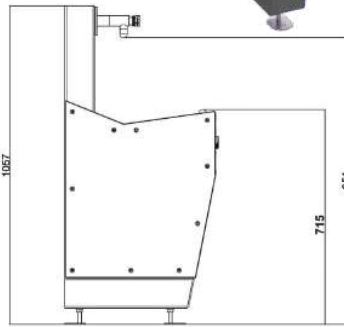

### + CF400 Premium Floor Mounted - Bubbler Height 715mm

#### FEATURES

- + Chiller Unit - 72 L/hour chilling capacity
- + Includes filter for improved water quality
- + Stainless Steel Modular Construction
- + 3 x Bottle Filler
- + 3 x Drinking Bubblers
- + 316 S/S Trough and Fixings
- + Easy Activated push buttons
- + Floor Mounted (approx. bubbler height at 715mm)
- + 240V Electrical supply
- + Australian Made
- + Vandal resistant
- + Easy Installation
- + Signage or logo panel with branding

#### OPTIONS

- + Over 100 Powder Coating options
- + Non-Chilled.

#### DIMENSIONS

- + Total Height Approx: 1057mm
- + Width: 1625mm
- + Depth: 497mm

+ SKU DF\_CF400\_P\_SM

Laser- Etched  
Sign

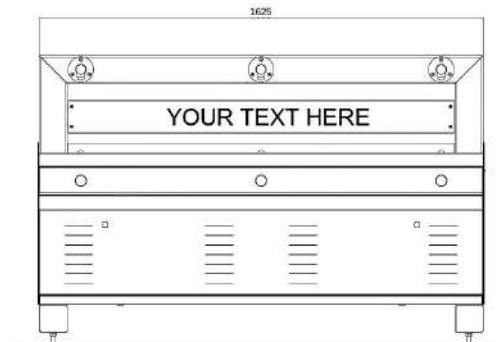
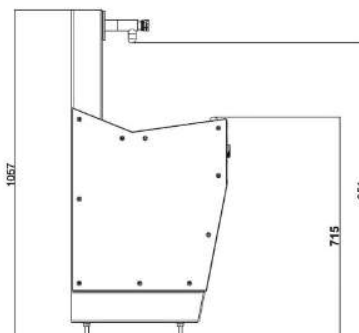

# CF400 PRODUCT CATALOGUE

## Floor Mounted

### + CF400 Standard Floor Mounted - Bubbler Height 715mm with DDA Basin

#### FEATURES

- + Chiller Unit - 72 L/hour chilling capacity
- + Includes filter for improved water quality
- + Stainless Steel Modular Construction
- + 3 x Bottle Filler
- + 3 x Drinking Bubblers
- + 316 S/S Trough and Fixings
- + Easy Activated push buttons
- + Floor Mounted (approx. bubbler height at 715mm)
- + 240V Electrical supply
- + Australian Made
- + Vandal resistant
- + Easy Installation
- + DDA Basin

#### OPTIONS

- + Over 100 Powder Coating options.
- + Non-Chilled.

#### DIMENSIONS

- + Total Height Approx: 1057mm
- + Width: 2064mm

+ SKU DF\_CF400\_SM\_B

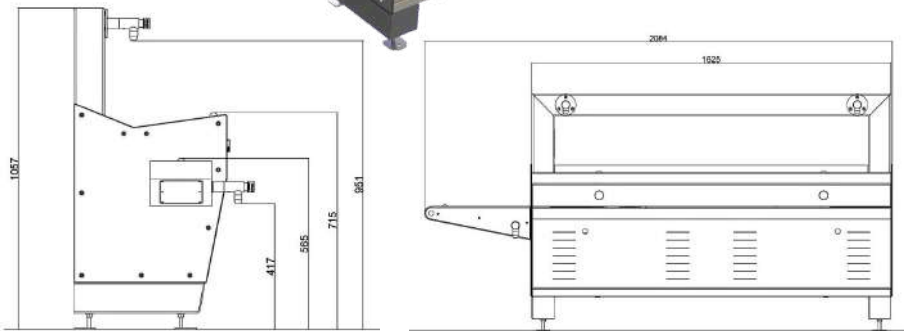
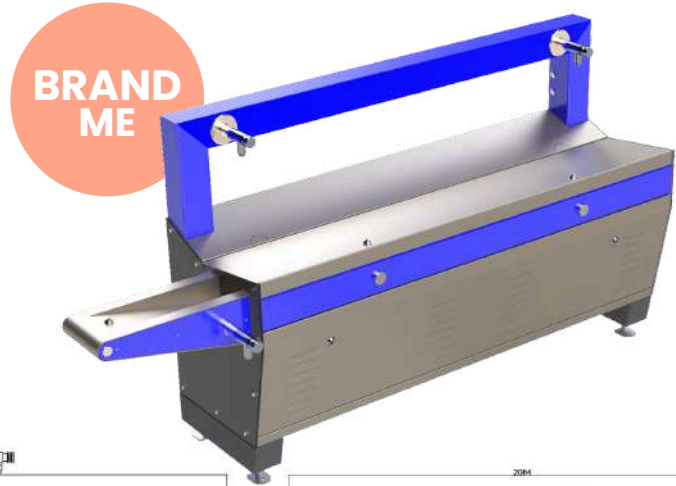

\*Note: Due to the height of the basin on this model, it does not comply with AS1428 accessibility standards.

### + CF400 Premium Floor Mounted - Bubbler Height 715mm with DDA Basin

#### FEATURES

- + Chiller Unit - 72 L/hour chilling capacity
- + Includes filter for improved water quality
- + Stainless Steel Modular Construction
- + 3 x Bottle Filler
- + 3 x Drinking Bubblers
- + 316 S/S Trough and Fixings
- + Easy Activated push buttons
- + Floor Mounted (approx. bubbler height at 715mm)
- + 240V Electrical supply
- + Australian Made
- + Vandal resistant
- + Easy Installation
- + Signage or logo panel with branding
- + DDA Basin

#### OPTIONS

- + Over 100 Powder Coating options.
- + Non-Chilled.

#### DIMENSIONS

- + Total Height Approx: 1057mm
- + Width: 2064mm

+ SKU DF\_CF400\_P\_SM\_B

Laser- Etched  
Sign

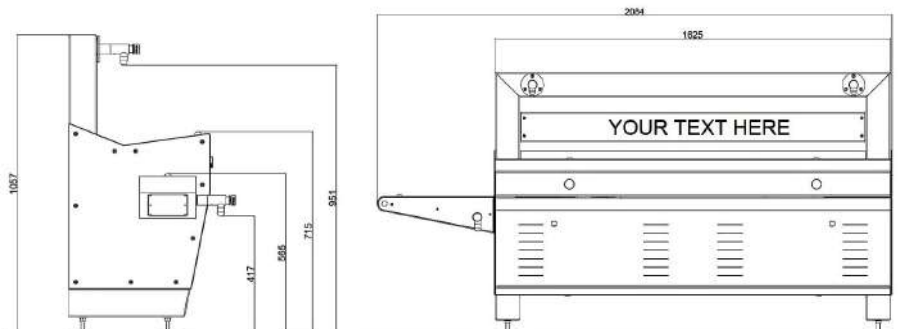
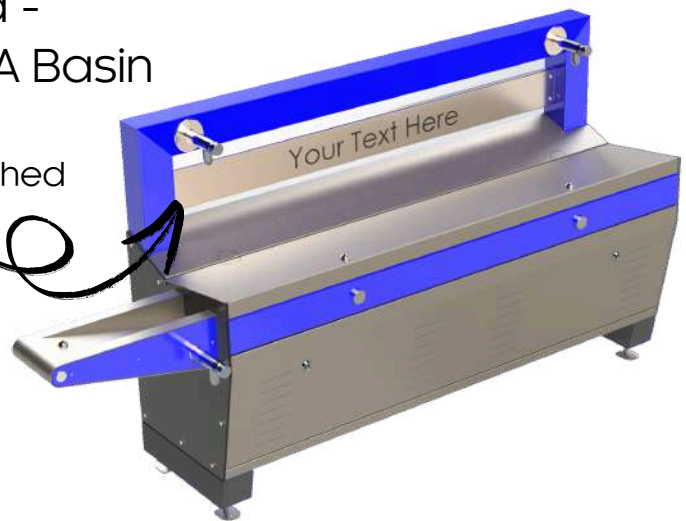

\*Note: Due to the height of the basin on this model, it does not comply with AS1428 accessibility standards.

# CF400 FLOOR MOUNTED OPTIONS

Ideal for Seniors and Sports Clubs



# WHY CHOOSE FLOOR MOUNTED?

The CF400 floor-mounted version also offers a variation suitable for seniors, with the bubbler set at 907 mm. This higher placement is tailored to older students and adults, ensuring comfortable access to both the bubbler and bottle fillers.

- + Floor-mounted units transfer weight directly to the floor, making them ideal for buildings with walls that aren't designed to support heavy wall-mounted fountains.
- + With floor-mounted units, extensive wall cutouts and reinforcements are unnecessary, making installation simpler and less invasive.
- + When facility layouts change, floor-mounted units can be removed and relocated with ease.

# CF400 PRODUCT CATALOGUE

## Floor Mounted

### + CF430 Standard Floor Mounted - Bubbler Height 907mm

#### FEATURES

- + Chiller Unit - 72 L/hour chilling capacity
- + Includes filter for improved water quality
- + Stainless Steel Modular Construction
- + 3 x Bottle Filler
- + 3 x Drinking Bubblers
- + 316 S/S Trough and Fixings
- + Easy Activated push buttons
- + Floor Mounted (approx. bubbler height at 907mm)
- + 240V Electrical supply
- + Australian Made
- + Vandal resistant
- + Easy Installation

#### OPTIONS

- + Over 100 Powder Coating options.
- + No-Chilled.

#### DIMENSIONS

- + Total Height Approx: 1250mm
- + Width: 1625mm
- + Depth: 497mm

+ SKU DF\_CF430

BRAND  
ME

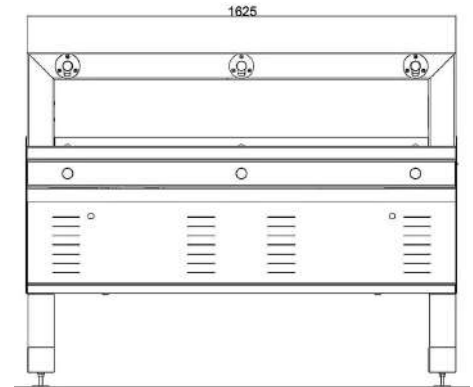
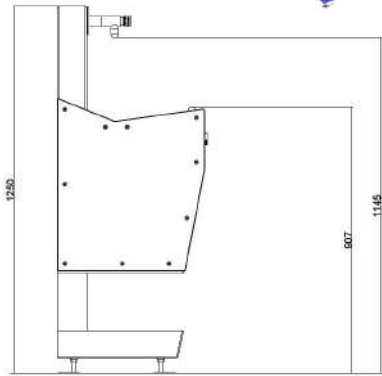
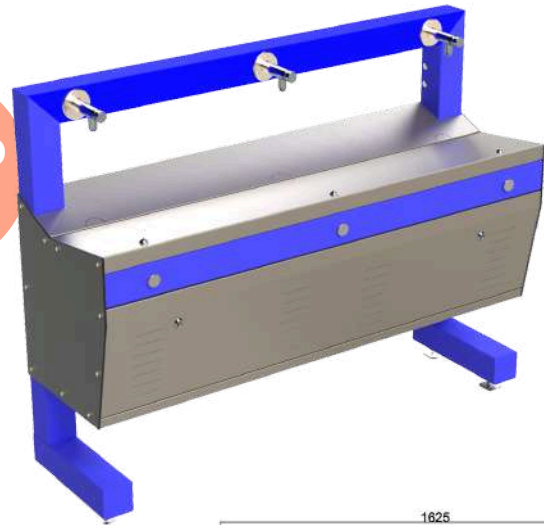

### + CF430 Premium Floor Mounted - Bubbler Height 907mm

#### FEATURES

- + Chiller Unit - 72 L/hour chilling capacity
- + Includes filter for improved water quality
- + Stainless Steel Modular Construction
- + 3 x Bottle Filler
- + 3 x Drinking Bubblers
- + 316 S/S Trough and Fixings
- + Easy Activated push buttons
- + Floor Mounted (approx. bubbler height at 907mm)
- + 240V Electrical supply
- + Australian Made
- + Vandal resistant
- + Easy Installation
- + Signage or logo panel with branding

#### OPTIONS

- + Over 100 Powder Coating options.
- + Non-Chilled.

#### DIMENSIONS

- + Total Height Approx: 1250mm
- + Width: 1625mm
- + Depth: 497mm

+ SKU DF\_CF430\_P

Laser-Etched  
Sign

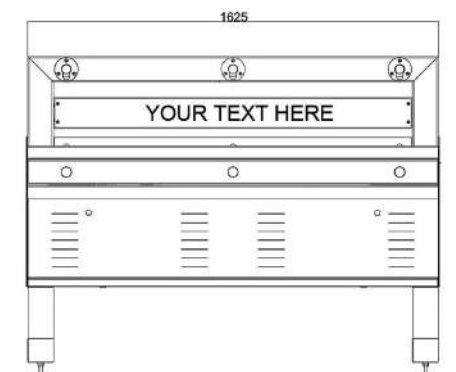
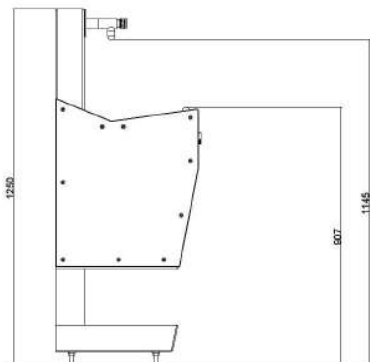

# CF400 PRODUCT CATALOGUE

## Floor Mounted

### + CF430 Standard Floor Mounted - Bubbler Height 907mm with DDA Basin

#### FEATURES

- + Chiller Unit - 72 L/hour chilling capacity
- + Includes filter for improved water quality
- + Stainless Steel Modular Construction
- + 3 x Bottle Filler
- + 3 x Drinking Bubblers
- + 316 S/S Trough and Fixings
- + Easy Activated push buttons
- + Floor Mounted (approx. bubbler height at 907mm)
- + 240V Electrical supply
- + Australian Made
- + Vandal resistant
- + Easy Installation
- + DDA Basin

#### OPTIONS

- + Over 100 Powder Coating options.
- + Non-Chilled.

#### DIMENSIONS

- + Total Height Approx: 1250mm
- + Width: 2084mm

+ SKU DF\_CF430\_B

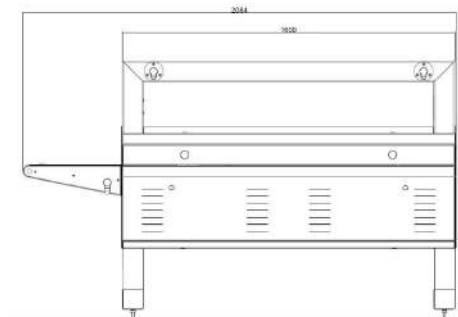
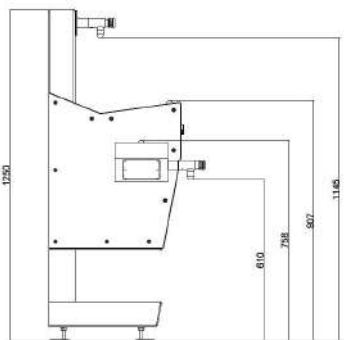
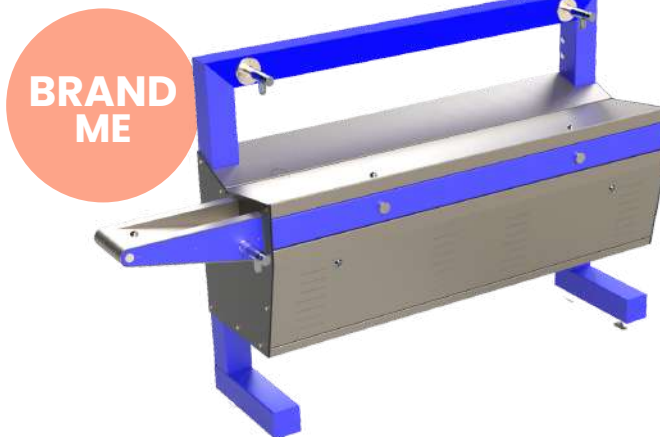

### + CF430 Premium Floor Mounted - Bubbler Height 907mm with DDA Basin

#### FEATURES

- + Chiller Unit - 72 L/hour chilling capacity
- + Includes filter for improved water quality
- + Stainless Steel Modular Construction
- + 3 x Bottle Filler
- + 3 x Drinking Bubblers
- + 316 S/S Trough and Fixings
- + Easy Activated push buttons
- + Floor Mounted (approx. bubbler height at 907mm)
- + 240V Electrical supply
- + Australian Made
- + Vandal resistant
- + Easy Installation
- + Signage or logo panel with branding
- + DDA Basin

#### OPTIONS

- + Over 100 Powder Coating options.
- + Non-Chilled.

#### DIMENSIONS

- + Total Height Approx: 1250mm
- + Width: 2084mm

+ SKU DF\_CF430\_P\_B

Laser- Etched  
Sign

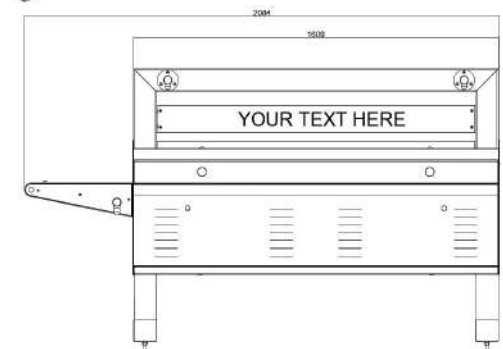
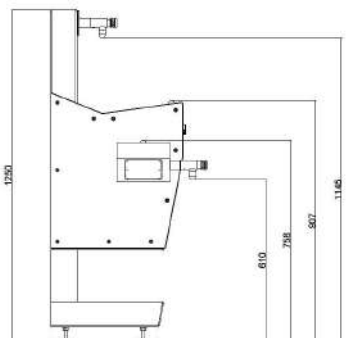
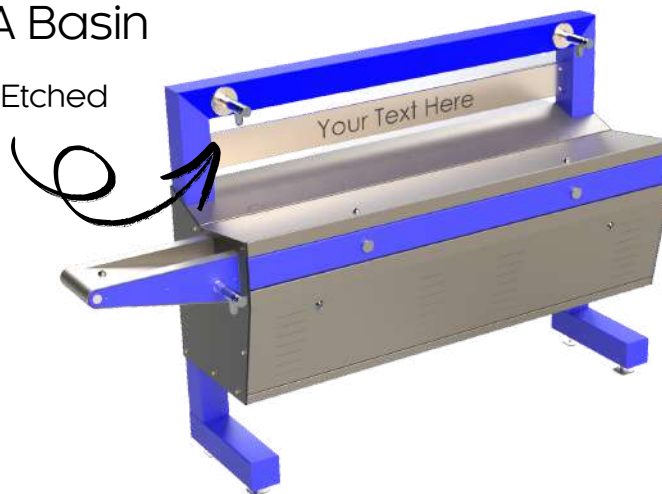

# CF400 COMPACT WALL & FLOOR MOUNTED

Ideal for Junior and Seniors



# WHY CHOOSE COMPACT?

Schools with limited space often choose the compact CF400 for its reduced footprint, which helps conserve space in crowded hallways or common areas. Usually catering to smaller schools, it still provides reliable water access for students, making it a practical choice for educational environments with limited room.

- + Reduced footprint allows for easy installation in hallways or smaller common areas.
- + The compact models generally come at a more budget-friendly price point, making it an economical choice.
- + Though smaller in size, the compact version still provides the reliable water access students and staff require.

# CF400 PRODUCT CATALOGUE

## Wall Mounted Compact

### + CF420 Standard Wall Mounted

#### FEATURES

- + Chiller Unit - 72 L/hour chilling capacity
- + Includes filter for improved water quality
- + Stainless Steel Modular Construction
- + 2 x Bottle Filler
- + 2 x Drinking Bubblers
- + 316 S/S Trough and Fixings
- + Easy Activated push buttons
- + Wall Mounted (height can vary to suit requirements)
- + 240V Electrical supply
- + Australian Made
- + Vandal resistant
- + Easy Installation

#### OPTIONS

- + Over 100 Powder Coating options.
- + Non-Chilled.

#### DIMENSIONS

- + Total Height: 900mm
- + Width: 1214mm
- + Depth: 497mm

+ SKU DF\_CF420

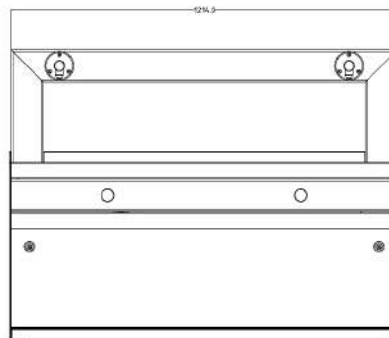
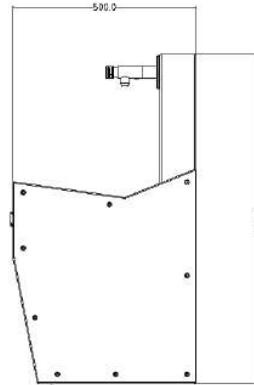

BRAND  
ME



### + CF420 Premium Wall Mounted

#### FEATURES

- + Chiller Unit - 72 L/hour chilling capacity
- + Includes filter for improved water quality
- + Stainless Steel Modular Construction
- + 2 x Bottle Filler
- + 2 x Drinking Bubblers
- + 316 S/S Trough and Fixings
- + Easy Activated push buttons
- + Wall Mounted (height can vary to suit requirements)
- + 240V Electrical supply
- + Australian Made
- + Vandal resistant
- + Easy Installation
- + Signage or logo panel with branding

#### OPTIONS

- + Over 100 Powder Coating options.
- + Non-Chilled.

#### DIMENSIONS

- + Total Height: 900mm
- + Width: 1214mm
- + Depth: 497mm

+ SKU DF\_CF420\_P

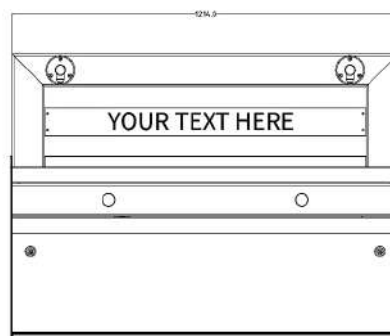
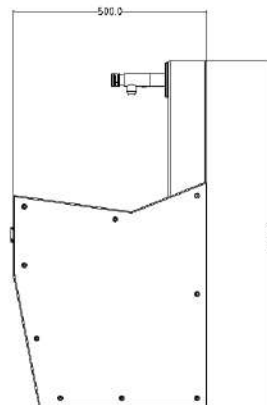

Laser- Etched  
Sign



# CF400 PRODUCT CATALOGUE

## Wall Mounted Compact

### + CF410 Standard Wall Mounted

#### FEATURES

- + Chiller Unit - 19 L/hour chilling capacity
- + Includes filter for improved water quality
- + Stainless Steel Modular Construction
- + 1 x Bottle Filler
- + 1 x Drinking Bubblers
- + 316 S/S Trough and Fixings
- + Easy Activated push buttons
- + Wall Mounted (height can vary to suit requirements)
- + 240V Electrical supply
- + Australian Made
- + Vandal resistant
- + Easy Installation

#### OPTIONS

- + Over 100 Powder Coating options.
- + Non-Chilled.

#### DIMENSIONS

- + Total Height: 900mm
- + Width: 600mm
- + Depth: 497mm

+ SKU DF\_CF410

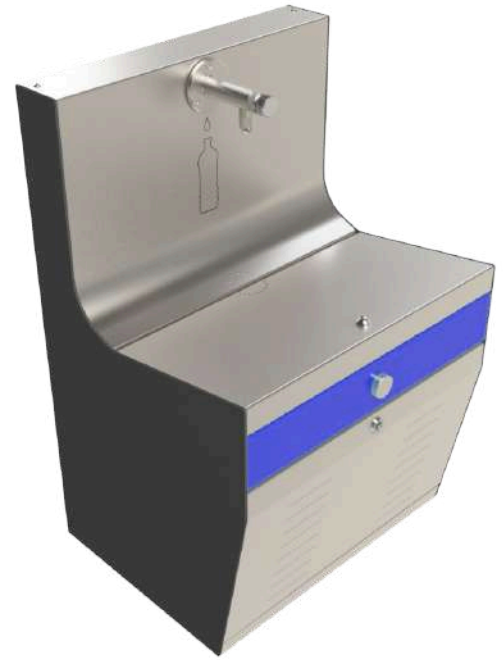
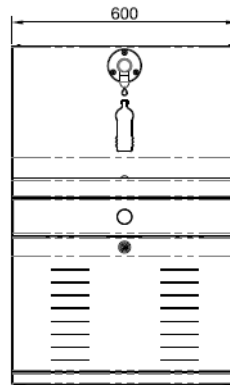
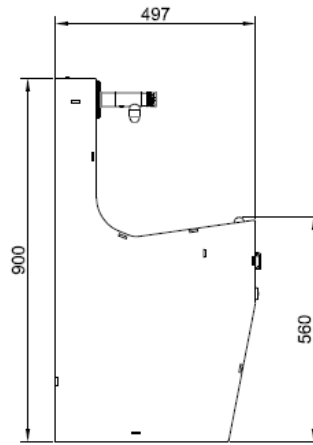

## CUSTOM COLOURS TO MATCH!

Urban + offers the full Dulux range, with around 100 colours available for the CF400. Both the body and front button plate can be customised separately, allowing schools to mix and match colours to align with their logo or branding.

Whether you're looking to match your school or club's colours or create a unique combination, we've got you covered!

#### POPULAR COLOURS



COAST



STORM



DESERT



FLAME



LEAF



EVERGREEN



MONUMENT



SILVER



MOONLIGHT



SUNSHINE



REEF

# CF400 PRODUCT CATALOGUE

## Floor Mounted Compact

### + CF420 Standard Floor Mounted - Bubbler Height 907mm

#### FEATURES

- + Chiller Unit - 72 L/hour chilling capacity
- + Includes filter for improved water quality
- + Stainless Steel Modular Construction
- + 2 x Bottle Filler
- + 2 x Drinking Bubblers
- + 316 S/S Trough and Fixings
- + Easy Activated push buttons
- + Floor Mounted (approx. bubbler height at 907mm)
- + 240V Electrical supply
- + Australian Made
- + Vandal resistant
- + Easy Installation

#### OPTIONS

- + Over 100 Powder Coating options.
- + Non-Chilled.

#### DIMENSIONS

- + Total Height Approx: 1250mm
- + Width: 1214mm
- + Depth: 497mm

+ SKU DF\_CF420\_FM

BRAND  
ME

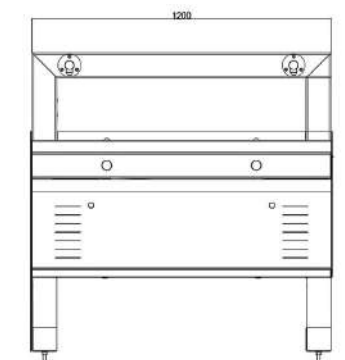
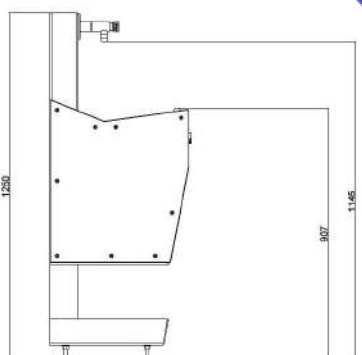

### + CF420 Premium Floor Mounted - Bubbler Height 907mm

#### FEATURES

- + Chiller Unit - 72 L/hour chilling capacity
- + Includes filter for improved water quality
- + Stainless Steel Modular Construction
- + 3 x Bottle Filler
- + 3 x Drinking Bubblers
- + 316 S/S Trough and Fixings
- + Easy Activated push buttons
- + Floor Mounted (approx. bubbler height at 907mm)
- + 240V Electrical supply
- + Australian Made
- + Vandal resistant
- + Easy Installation
- + Signage or logo panel with branding

#### OPTIONS

- + Over 100 Powder Coating options.
- + Non-Chilled.

#### DIMENSIONS

- + Total Height Approx: 1250mm
- + Width: 1214mm
- + Depth: 497mm

+ SKU DF\_CF420\_P\_FM

Laser- Etched  
Sign

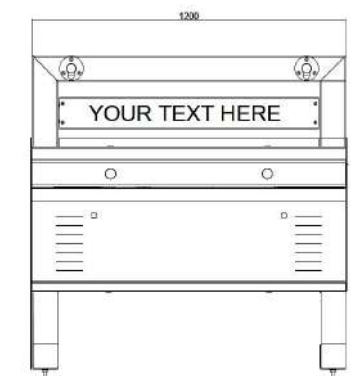
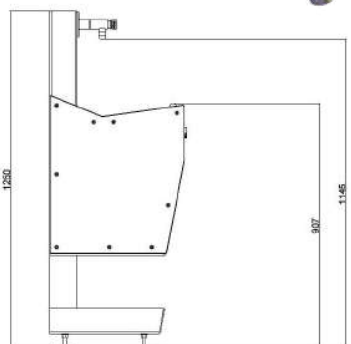

# CF400 PRODUCT CATALOGUE

## Floor Mounted Compact

### + CF420 Standard Floor Mounted – Bubbler Height 715mm

BRAND  
ME

#### FEATURES

- + Chiller Unit - 72 L/hour chilling capacity
- + Includes filter for improved water quality
- + Stainless Steel Modular Construction
- + 2 x Bottle Filler
- + 2 x Drinking Bubblers
- + 316 S/S Trough and Fixings
- + Easy Activated push buttons
- + Floor Mounted (approx. bubbler height at 715mm)
- + 240V Electrical supply
- + Australian Made
- + Vandal resistant
- + Easy Installation

#### OPTIONS

- + Over 100 Powder Coating options.
- + Non-Chilled.

#### DIMENSIONS

- + Total Height Approx: 1057mm
- + Width: 1200mm
- + Depth: 497mm

+ SKU DF\_CF420\_SM

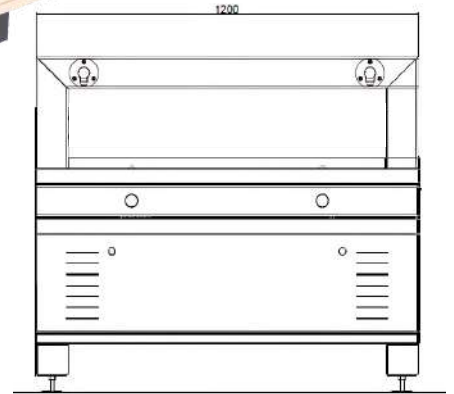
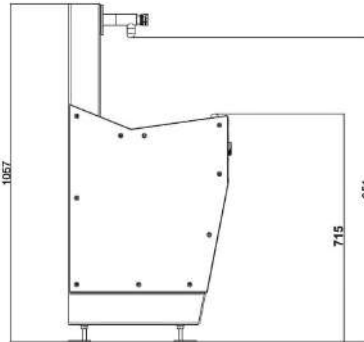

### + CF420 Premium Floor Mounted – Bubbler Height 715mm

#### FEATURES

- + Chiller Unit - 72 L/hour chilling capacity
- + Includes filter for improved water quality
- + Stainless Steel Modular Construction
- + 2 x Bottle Filler
- + 2 x Drinking Bubblers
- + 316 S/S Trough and Fixings
- + Easy Activated push buttons
- + Wall Mounted (height can vary to suit requirements)
- + 240V Electrical supply
- + Australian Made
- + Vandal resistant
- + Easy Installation
- + Signage or logo panel with branding

#### OPTIONS

- + Over 100 Powder Coating options.
- + Non-Chilled.

#### DIMENSIONS

- + Total Height Approx: 1057mm
- + Width: 1200mm
- + Depth: 497mm

+ SKU DF\_CF420\_P\_SM

Laser- Etched  
Sign

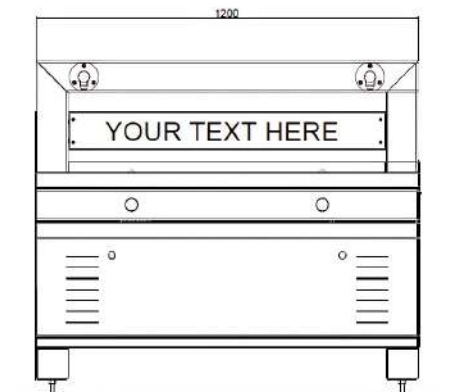
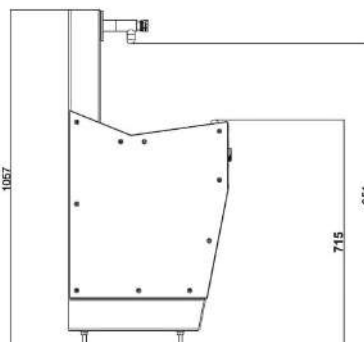

# CF400 PRODUCT CATALOGUE

## Meet Our Chiller Unit

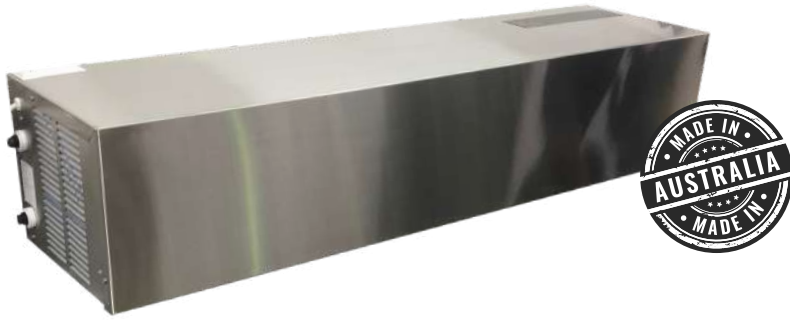

## Market Leading Chiller Unit

Experience premium hydration with the Urban + preferred chiller, seamlessly integrated into our CF400, CF420, and CF430 Hydration Stations. Expertly engineered from robust stainless steel, it effortlessly provides up to **72 litres of crisp, chilled water per hour.**

## Description and Features

- + This water cooler is fitted with a low ambient temperature control to help prevent the refrigeration system from running in cooler weather (21 degrees C or below) and extending the life of the refrigeration system. *Children don't need to be drinking cold water when the outside temperature is below 21 degrees C.*
- + All the electrical wiring is double insulated.  
All water lines and fittings are insulated to prevent condensation.
- + Will produce approximately 72 litres of cold water per hour.

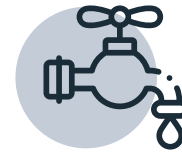

**Water Supply**  
Mains Water Supply



**Cooling System**  
R134a refrigerant,  
compressor



**Power Supply**  
220/240volt, 50hz,  
1ph, 2.6 amps,  
395 watts, IP33



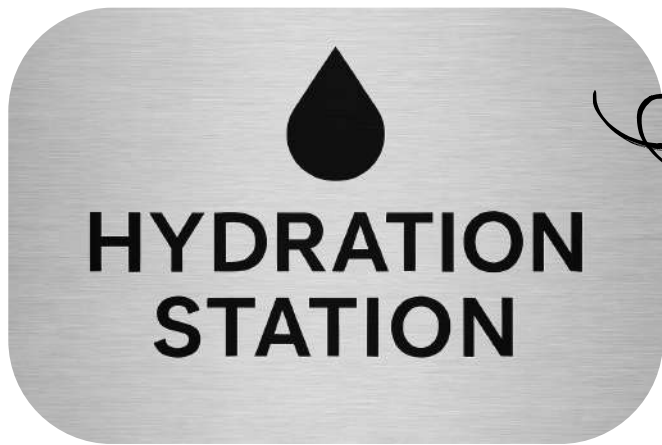

## Laser-Etched Custom Signs

Custom signs quickly convey your identity, create lasting impressions, and enhance the look of your fountain, but at Urban we make sure it lasts. Our precision laser-etched signs are made from robust materials, ensuring your sign stays sharp and visually appealing, thus ensuring your investment lasts.

## Why choose Laser-Etched?

- + **Durability:** Permanent and highly resistant to fading, peeling, and scratching.
- + **Quality & Precision:** Extremely detailed, sharp, and clean, suitable for intricate logos and designs. Customised to your needs.
- + **Premium Look:** Offers a high-end, professional appearance.
- + **Maintenance:** Minimal to no maintenance required; easy to clean and maintain long-term.



### + GENERAL

#### ? Will it be strong enough for school use?

Absolutely! With a strong background in outdoor street furniture, Urban designs and manufactures durable, long-lasting products. Our custom-designed tapware and reinforced features make the CF400 ideal for high-traffic environments like busy schools.

#### ? What are the key considerations when locating the unit

- + Is there easy access to water and power
- + Will the unit be wall or floor mounted
- + What height does the unit need to sit at
- + Is there a need to meet AS1428 standards

#### ? What about DDA requirements?

Urban + has designed a DDA-compliant basin that seamlessly attaches to the side of the CF400 drinking fountain, ensuring accessibility for all users and meeting the AS1428 standards for disability access. This innovative addition provides a comfortable and convenient drinking experience for individuals with mobility impairments, including those using wheelchairs or mobility aids.

For installations where the CF400 is wall-mounted, it is important to ensure that the fountain height complies with AS1428 requirements to maintain full DDA compliance. Proper positioning guarantees that users can easily access the water source while ensuring adherence to Australian accessibility standards.



### + FEATURES AND OPTIONS

#### ? How many bubblers and bottle fillers does it have?

The CF400 comes standard with three bubblers and three bottle fillers. In response to interest from schools, we now offer a 2-Tap version, featuring two drinking bubblers and two bottle fillers. Additionally, a separate model with a single tap and single bubbler is available

#### ? Do I have to have the signage?

Signage is optional, and schools can choose to include it now or add it later if they decide to go down that path in the future.

#### ? What can I have on the signage?

Schools can customise the design with any wording or characters. However, more characters mean smaller text to fit the space. Options are endless—some schools choose musical notes, their name, or input from students and parents for a unique touch. Please note that elaborate designs and colours may come at an additional fee.

#### ? What colour are the characters on the centre strip?

Black is the most popular choice, but other colours are available. We're happy to provide guidance on options to help find the best fit.

#### ? What are my colour options for the CF400?

Urban + offers the full Dulux range, with around 100 colours available for the CF400. Both the body and front button plate can be customised separately, allowing schools to mix and match colours to align with their logo or branding.



### + PLUMBING

#### ? Does the unit have a filter?

Yes, the CF400 comes standard with a filter. Replacement depends on water usage and incoming water quality, but we recommend changing it at least once every 12 months for optimal performance.

#### ? How does the waste work?

The drip tray is designed to catch excess water and direct it to a waste outlet for proper drainage. It is both removable and reversible, allowing for a left or right fall depending on the fountain's placement and the waste outlet location.

#### ? How does the chiller work?

Urban has selected an Australian-made, high-capacity chiller capable of cooling up to 72L per hour. To ensure consistent water flow and pressure, the CF400 features ½-inch plumbing, allowing all six outlets to be used simultaneously without compromising performance.

#### ? Can I have it without a chiller?

Yes, the CF400 is available with or without a chiller, depending on your needs.

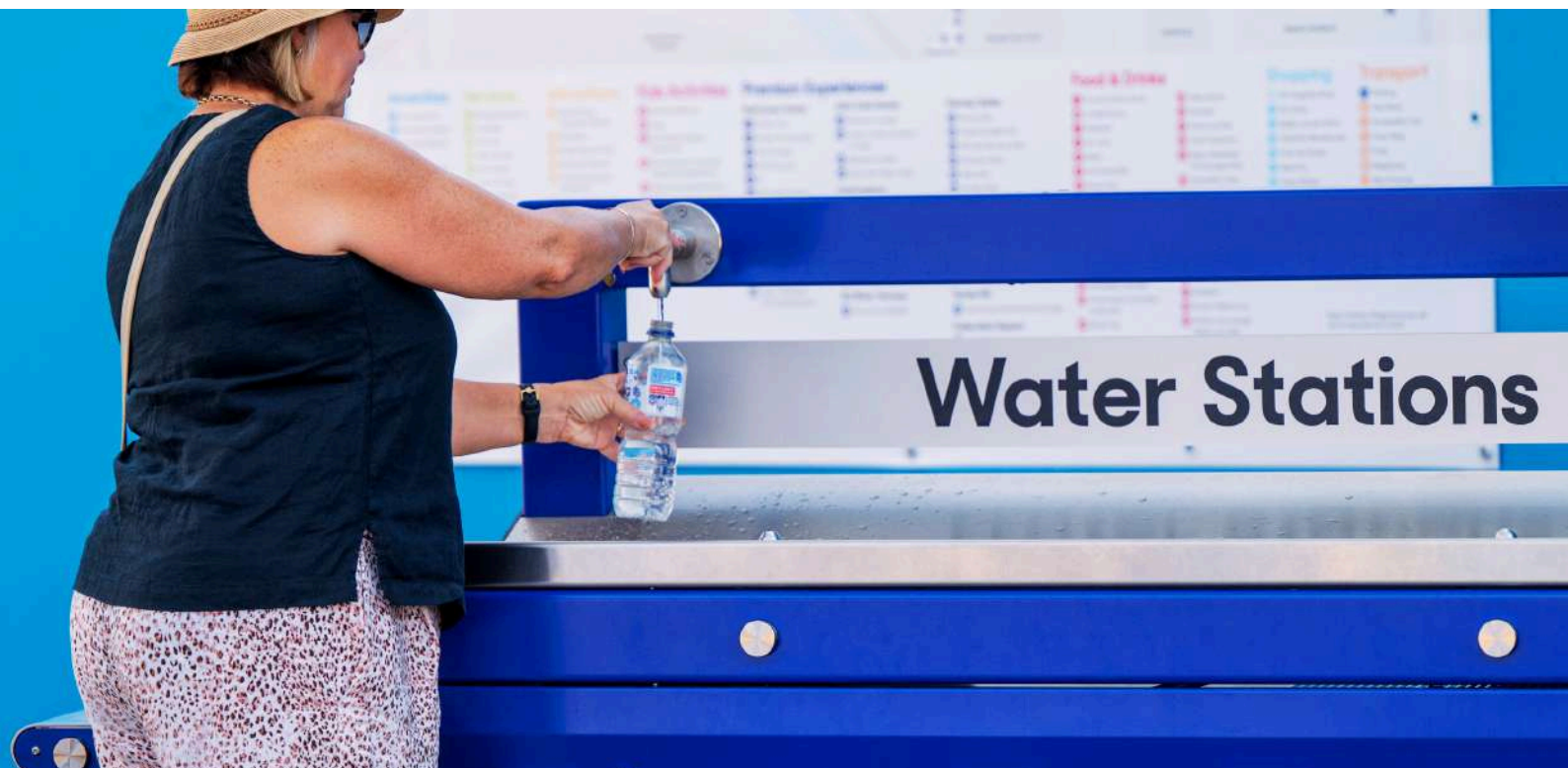

### + INSTALLATION

#### ? Does the unit have to get mounted on a wall?

No, the CF400 does not have to be wall-mounted. There are floor-mounting options available, depending on your needs. Both must be securely and permanently fixed to the floor for safety and stability once installed.

#### ? How high should it be mounted

Since the CF400 is designed for both junior and senior students, the height is crucial to ensure easy access to the bubblers and bottle fillers. For proper installation, a minimum clearance of 150mm at the base is required to allow airflow and keep the chiller unit cool.

For junior schools, we recommend positioning the bubbler at approximately 715mm from the floor, while for seniors, the ideal height is around 907mm. However, schools may choose to adjust the height based on the age group of their students.

#### ? Is it difficult to install

No, installation is straightforward despite the unit's weight. The CF400 features a simple mounting system, but it does require a solid, structural wall as it weighs 150kg. If a suitable wall isn't available, a floor-mounted version is also an option.



### + MAINTENANCE

#### ? Is the unit difficult to clean

The CF400 is designed for easy cleaning and maintenance. The front access panel provides quick access to the chiller and filter for servicing. Regular cleaning and preventative maintenance are recommended to keep the unit in optimal working condition. Ongoing support for service and maintenance is available to ensure the CF400 continues to perform at its best.

#### ? What happens if the unit gets sand or dirt in it

Occasionally, unwanted debris may find its way into the unit. That's why Urban has designed the CF400 for easy access, allowing for quick cleaning and maintenance to get it back in working order as fast as possible.

#### ? Do you offer installation/maintenance service?

We provide installation and maintenance services, depending on your location. Our team can assist with professional setup and ongoing servicing to ensure your unit remains in optimal condition. Get in touch with us for more details on availability and support in your area.

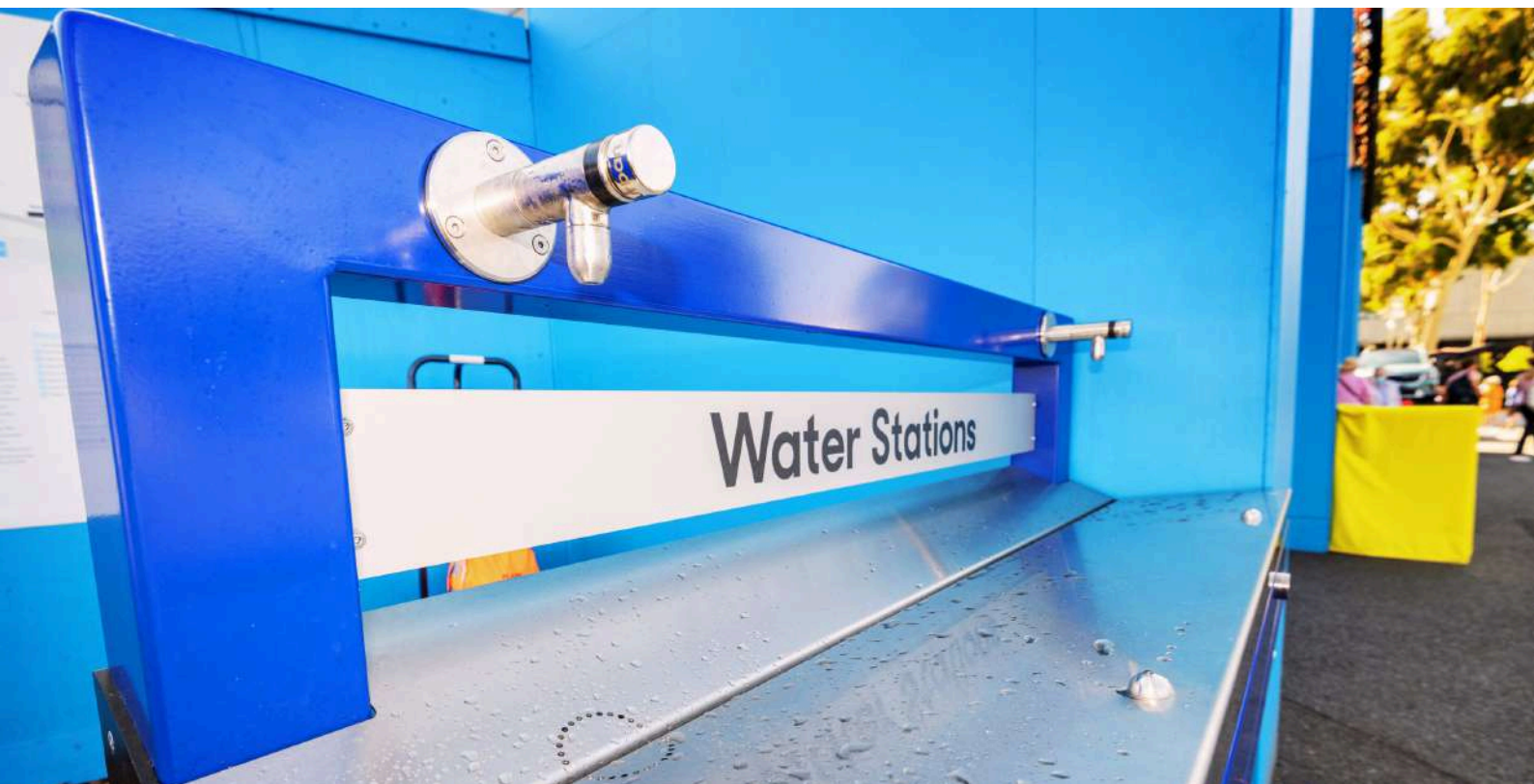

### VANDALISM PROTECTION & WARRANTY

Urban + has been designing and manufacturing drinking fountains for over 20 years, specialising in durable solutions built to withstand all weather conditions and high-traffic environments. With extensive experience in creating fountains for vandal-prone areas, we design our products to be robust and resilient. While no design can completely prevent damage from determined vandals, our high-strength construction significantly reduces the risk of serious or lasting harm.

#### Key Features to Prevent Vandalism:

**+ Material Thickness:** We use the thickest materials possible while maintaining aesthetic appeal to ensure robustness.

**+ Secure Tapware:** All custom-designed tapware is secured with additional mounting collars, which are fully fillet-welded internally to resist any attempts at forced removal. For added durability, reinforced stainless steel bars are incorporated to prevent intentional damage and breakage, ensuring long-lasting performance.

**+ Hidden Fixings:** We minimise visible external screws, with most fixings concealed internally for a cleaner, more secure design. Any necessary external fixings are equipped with security screws to deter unauthorised tampering.

#### Warranty

All our fountains are proudly designed and manufactured in Australia, showcasing our commitment to quality craftsmanship and exceptional customer service. We offer comprehensive support, including assistance with installation inquiries, after-sales service, and replacement parts if needed.

Built for long-term durability, each unit undergoes rigorous quality control and water testing before dispatch. Most plumbing fittings are standard and readily available at plumbing stores, while Urban Valves and bottle fillers can be sourced directly from our factory.

We stand by our products with a standard 2-year warranty on all manufactured and plumbing components, and our fountains are designed to last over 15 years with proper care and maintenance.

### ABOUT URBAN+ FOUNTAINS & FURNITURE

#### + COMPANY HISTORY

Urban was founded in 2001 by husband-and-wife team Gary and Claire Allan, who recognised an opportunity to create durable and timeless street and park furniture.

Urban+ operated for 18 years on respect, reputation, and strong working relationships.

In 2019 Simon Higgins was brought on as a business partner and helped define Urban+'s purpose to support the shift to a circular economy.

Urban+ now integrates circular thinking into every aspect of its business and manufacturing processes, driving the shift towards a truly sustainable Australian manufacturing industry.

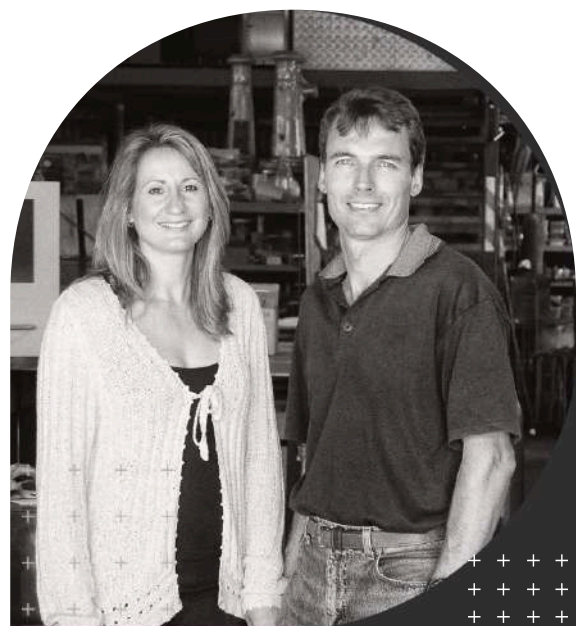

# CF400 PRODUCT CATALOGUE

Making Life Better

## WHAT IS THE CIRCULAR ECONOMY?

### + THE CIRCULAR ECONOMY EXPLAINED

The concept of a Circular Economy gained traction in the 1970s, describing a system that minimises waste and pollution while keeping materials in use for as long as possible.

This approach stands in sharp contrast to the traditional "linear" or "take-make-waste" model, which depletes natural resources and harms ecosystems worldwide.

At Urban+, we combine exceptional design with sustainability. Our commitment to a circular economy ensures our products are visually striking, durable, and eco-friendly. By emphasising craftsmanship, we create innovative solutions that enhance public spaces and minimise waste for a sustainable future.



## SCHOOLS WHO HAVE TRUSTED URBAN + HYDRATION SOLUTIONS.



# CONTACT URBAN+

Please Note: The products featured in this brochure represent only a part of our extensive range. To explore our full collection of drinking fountains, bottle refill stations, and outdoor furniture solutions, please visit our website by scanning the QR code.

 **(07) 3382 7372**

---

 **office@urbanff.com.au**

---

 **5 Telford Circuit, Yatala, QLD**

---

 **schools.urbanff.com.au**

---



**urban** +  
**for schools**

[schools.urbanff.com.au](https://schools.urbanff.com.au)